



TECHNICAL GUIDE

HORIZONTAL DISCHARGE SPLIT SYSTEM AIR CONDITIONERS

**14 SEER – R-410A – 3 PHASE
3, 4 NOMINAL TONS
MODELS: TCHE36, 48**

FOR INSTALLATION IN ALL US REGIONS AND CANADA



ISO 9001
Certified Quality
Management System



Due to continuous product improvement, specifications are subject to change without notice.

Visit us on the web at

www.simplygettingthejobdone.com and
www.york.com

Additional rating information can be found at

www.ahridirectory.org

WARRANTY SUMMARY*

Standard 1-Year limited parts warranty.

Standard 5-Years limited compressor warranty.

*Does not apply to Internet sales.

See Limited Warranty certificate in User's Information Manual for details.

DESCRIPTION

The 14 SEER TCHE Series condensing unit is the outdoor part of a versatile system of air conditioning. Optimized for the new 14 SEER Regional Minimum Efficiency and the high EER required in the Southwest US, these outdoor units are specifically designed to be matched with York indoor coils, furnaces, and air handlers to provide a complete system solution.

These remarkably compact units require only minimal service and airflow clearances, allowing them to be positioned as close as six inches (6") from the wall. This design allows the unit to be located virtually anywhere – on the ground, roof, balcony, or mounted to an outside wall. When installation footprint is limited, these units can be stacked two-high using the approved stacking kit.

FEATURES

- **Performance** - Optimized for the US DOE Southwest Region and valid for installation in all US DOE Regions.
- **Small Footprint** - Compact "slim-line" design allows for easy installation in tight spaces. Units can be stacked two-high with approved stacking kit.
- **QuietDrive™ System** - The combination of a swept-wing fan, rigid base pan, isolated compressor compartment, and quiet scroll compressor reduce sound to as low as 70 dBA.
- **Low Operating Sound Levels** - The swept-wing condenser fan in blow-through configuration provides for whisper-quiet operation by allowing air to flow smoothly and efficiently across the fan blades.
- **Quality Condenser Coils** - The coil is constructed of aluminum microchannel tubing and enhanced aluminum fins for compact size and increased efficiency.
- **Environmentally Friendly Refrigerant** - The next generation refrigerant R-410A delivers environmentally friendly performance with zero ozone depletion.
- **Durable Cabinet** - Heavy-gauge steel cabinet and tubular base rails provide added support.
- **Aesthetic Appearance** - Powder paint "Champagne" color provides an attractive retail finish.
- **Agency Listed** - Safety certified by CSA to UL 1995 / CSA 22.2. Performance certified to ANSI/AHRI Standard 210/240 in accordance with the Unitary Small Equipment certification program.
- **Other Features:**
 - Factory installed filter drier
 - High pressure and low pressure switches
 - Accumulator and crankcase heater in all sizes
 - Up to 200' line set out of the box
 - Zero lot line - only 6" minimum clearance from structure

LIST OF SECTIONS

DESCRIPTION 1
FEATURES 1
NOMENCLATURE 2
PHYSICAL AND ELECTRICAL DATA 3
DIMENSIONS 3
SYSTEM CHARGE FOR VARIOUS MATCHED SYSTEMS 4
COOLING CAPACITY - With Air Handler Coils 4
COOLING CAPACITY - Upflow, Downflow & Horizontal Furnaces and Coils (Coil Only Ratings) 4
COOLING CAPACITY - With High Efficiency Motor Furnaces ... 5
APPLICATIONS AND ACCESSORIES 8
SOUND POWER RATINGS 8
MECHANICAL SPECIFICATIONS 9
TYPICAL INSTALLATION 10
MOUNTING HOLE GRAPHIC 10
TYPICAL FIELD WIRING 10
PERFORMANCE DATA - 3 TON 11
PERFORMANCE DATA - 4 TON 13

NOMENCLATURE

BRAND	T	T = Factory Branded
PRODUCT TYPE	C	C = Air Conditioner (US Northern or Southeast Region)
AIRFLOW	H	H = Horizontal Discharge
NOMINAL SERIES EFFICIENCY AND STAGING	E	E = 14 SEER High EER (US DOE Southwest Region)
NOMINAL UNIT CAPACITY (MBH)	36	36 = 3 Ton
		48 = 4 Ton
STAGING	S	S = Single Stage Compressor
REFRIGERANT	4	4 = R-410A Refrigerant
VOLTAGE (Voltage-Phase-Hertz)	3	3 = 208/230-3-60
		4 = 460-3-60
CONNECTION TYPE	S	S = Sweat Connect
GENERATION (MAJOR REVISION)	1	1 = 1st Gen
		2 = 2nd Gen
		etc
STYLE LETTER (MINOR REVISION) NOT USED FOR ORDERING	A	A = Style A
		B = Style B
		etc

PHYSICAL AND ELECTRICAL DATA

MODEL		TCHE36S43S1	TCHE48S43S1	TCHE36S44S1	TCHE48S44S1
Unit Supply Voltage		208-230V, 3 ϕ , 60Hz		460V, 3 ϕ , 60Hz	
Normal Voltage Range ¹		187 to 252		432 to 504	
Minimum Circuit Ampacity		12.5	18.5	8	8.56
Max. Overcurrent Device Amps ²		20	30	15	15
Min. Overcurrent Device Amps ³		15	20	15	15
Compressor Amps	Type	Scroll	Scroll	Scroll	Scroll
	Rated Load	9.0	13.8	5.8	6.2
	Locked Rotor	71.0	83.1	38.0	41.0
Crankcase Heater		Yes	Yes	Yes	Yes
Factory External Discharge Muffler		No	No	No	No
Factory External Check Valve		No	No	No	No
HS Kit Required with TXV ⁴		No	No	No	No
Fan Diameter Inches		23	23	23	23
Fan Motor	Rated HP	1/4	1/4	1/4	1/4
	Rated Load Amps	1.3	1.3	0.8	0.8
	Nominal RPM	850	850	850	850
	Nominal CFM	3200	3050	3200	3050
Coil	Face Area Sq. Ft.	11.96	13.96	11.96	13.96
	Rows Deep	1	1	1	1
	Fins / Inch	23	23	23	23
Refrigerant Lines ⁵	Max. Length	200	200	200	200
	Max. Lift	65	65	65	65
	Max. Drop	150	150	150	150
Liquid Line Set OD (Field Installed)		3/8	3/8	3/8	3/8
Vapor Line Set OD (Field Installed)		3/4	7/8	3/4	7/8
Unit Charge (Lbs. - Oz.) ⁶		6 - 6	7 - 4	6 - 6	7 - 4
Charge Per Foot, Oz.		0.62	0.67	0.62	0.67
Operating Weight Lbs.		200	225	200	225

1. Rated in accordance with AHRI Standard 110-2012, utilization range "A".
2. Dual element fuses or HACR circuit breaker. Maximum allowable overcurrent protection.
3. Dual element fuses or HACR circuit breaker. Minimum recommended overcurrent protection.
4. See Hard Start Kit Accessory Installation Manual for Hard Start Kit part number for each model.
5. When more than 50 feet of interconnecting tubing and more than 30 feet of vertical lift is used, consult the Application Data (part number 247077). For long-line applications, interconnecting lines over 100 feet must be installed with liquid line solenoid.
6. The Unit Charge is correct for the outdoor unit, smallest matched indoor unit, and 15 feet of refrigerant tubing. For tubing lengths other than 15 feet, add or subtract the amount of refrigerant, using the difference in length multiplied by the per foot value.

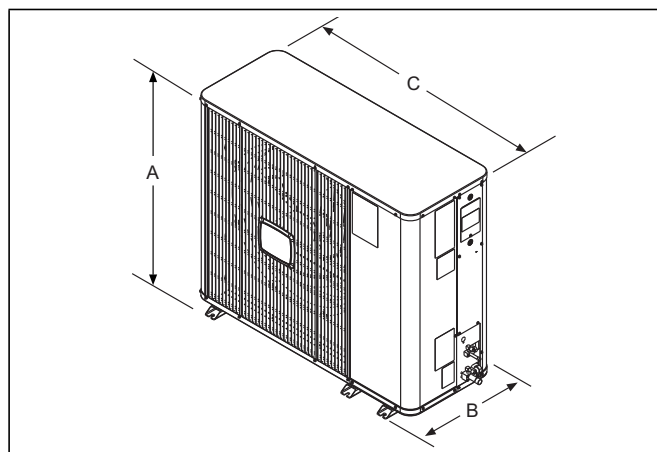

DIMENSIONS

Unit Model	Dimensions (Inches)			Refrigerant Connection Service Valve Size	
	A	B	C	Liquid	Vapor
TCHE36S4(3,4)S1	37-1/4	20	45	3/8	3/4
TCHE48S4(3,4)S1	43-1/4	20	45		7/8

All dimensions are in inches and are subject to change without notice.
 Overall height is from bottom of mounting feet to top of unit.
 Overall length and width include mounting feet and screw heads.

SYSTEM CHARGE FOR VARIOUS MATCHED SYSTEMS

Outdoor Unit	TCHE36S4(3,4)S1	TCHE48S4(3,4)S1
Required TXV ^{1,2}	BA2	BA2
Indoor Unit ^{3,4,5}	Additional Charge, Oz	
FC38C	0	—
FC49D	—	0

Some of the combinations shown in the above System Charge table require Advanced Main Air Circulating Fan indoor product. For approved coil only matches, please see the "COOLING CAPACITY - Upflow, Downflow & Horizontal Furnaces and Coils" table.

FOOTNOTES:

- For applications requiring a TXV use S1-1TVM*** series kit.
- A TXV kit must be used with these indoor units to obtain system performance.
- Systems matched with furnaces or air handlers not equipped with blower-off delays may require 60 second time delay.
- CF and FC coils cannot be used in horizontal applications.
- Charge adders shown above do not indicate that coils are rated for every application. Refer to Performance Data Tables for actual performance for specified system matches. Obtain certified system ratings from www.ahridirectory.org.

PROCEDURES:

- Check the Factory Unit Charge listed on the unit nameplate to verify the refrigerant charge for the outdoor unit, the smallest matched indoor unit, and the 15 feet of interconnecting lineset.
- Verify the indoor metering device and additional charge required for the specific matched indoor unit in the system using the above table.
- Add additional charge for the amount of interconnecting lineset greater than 15 feet at the rate specified in the Physical and Electrical Table.
- For installations requiring additional charge, weigh in refrigerant for the specific matching indoor unit and actual lineset length.
- Once the charge adders for matched indoor unit and for lineset have been weighed in, verify the system operation against the temperatures and pressures in the Charging Chart for the outdoor unit. Locate Charging Charts on the outdoor unit and also in the Service Data Application Guide on www.simplygettingthejobdone.com. Follow the Subcool or Superheat charging procedure in the Installation Manual according to the type of indoor metering device in the system, and allow ten minutes after each charge adjustment for the system operation to stabilize. Record the charge adjustment made to match the Charging Chart.
- Permanently stamp the unit data plate with the TOTAL SYSTEM CHARGE defined as follows: TOTAL SYSTEM CHARGE = Base Charge (as shipped) + charge adder for matched indoor unit + charge adder for actual lineset length + charge adjustments to match the Charging Chart.

COOLING CAPACITY - With Air Handler Coils

UNIT MODEL	AIR HANDLER		COIL MODEL ¹	COOLING				
	MODEL	WIDTH		RATED CFM	NET MBH		SEER	EER
					TOTAL	SENS.		
TCHE36S4(3,4)S1	ME16CN21	21.0	FC38C	1200	36.00	27.20	16.00	13.00
TCHE36S4(3,4)S1	MVC16CN21	21.0	FC38C	1200	35.80	27.20	15.50	12.75
TCHE36S44S1	ME12CN41	21.0	FC38C	1250	36.00	28.40	16.00	13.00
TCHE36S44S1	ME16CN41	21.0	FC38C	1100	36.00	26.80	16.00	13.00
TCHE48S4(3,4)S1	ME14DN21	24.5	FC49D	1425	46.50	34.60	15.10	12.50
TCHE48S4(3,4)S1	ME20DN21	24.5	FC49D	1425	46.50	34.60	15.50	12.50
TCHE48S44S1	ME20DN41	24.5	FC49D	1400	46.50	34.80	15.25	12.50
TCHE48S4(3,4)S1	MVC14DN21	24.5	FC49D	1175	45.50	31.80	15.50	12.75
TCHE48S4(3,4)S1	MVC20DN21	24.5	FC49D	1375	46.50	34.20	15.50	12.75

Rated in accordance with DOE test procedures (Federal Register 12-27-79 and 3-18-88) and ANSI/AHRI Standard 210/240.

Cooling MBH based on 80°F entering air temperature, 50% RH (Relative Humidity), and rated air flow.

EER (Energy Efficiency Ratio) is the total cooling output in BTUs at 95°F outdoor ambient divided by the total electric power in watt-hours at those conditions.

SEER (Seasonal Energy Efficiency Ratio) is the total cooling output in BTUs during a normal annual usage period for cooling divided by the total electric power input in watt-hours during the same period.

- CM coils available with a factory installed horizontal drain pan. See price pages for specific model number.

— = Not applicable.

MP Modular Air Handlers use Coil Only Ratings.

COOLING CAPACITY - Upflow, Downflow & Horizontal Furnaces and Coils (Coil Only Ratings)

UNIT MODEL	COIL		CFM RANGE (MIN.-MAX.)	COOLING				
	MODEL	WIDTH		RATED CFM	NET MBH		SEER ¹	EER
					TOTAL	SENS.		
TCHE36S4(3,4)S1	FC38C	21.0	1000 - 1400	1200	35.6	27.2	14.00	12.20
	FC38C	21.0	1000 - 1400	1200	35.6	27.2	14.00	12.20
TCHE48S4(3,4)S1	FC49D	21.0	1400 - 1800	1425	46.0	33.8	14.00	12.15
	FC49D	21.0	1400 - 1800	1425	46.0	33.8	14.00	12.15

For rated condition information, see the footnotes below the System Capacity - Single Piece and Modular Air Handlers table.

- Systems matched with furnaces or air handlers not equipped with blower-off delays may require 60 second time delay.

— = Not Applicable.

MP Modular Air Handlers use Coil Only Ratings.

PSC furnaces, such as the TG8S, TGLS, and TG9S, use Coil Only Ratings.

COOLING CAPACITY - With High Efficiency Motor Furnaces¹

UNIT MODEL	FURNACE		COIL MODEL ²	COOLING				
	MODEL	WIDTH		RATED CFM	NET MBH		SEER	EER
					TOTAL	SENS.		
TCHE36S4(3,4)S1	TL8E080C16UH11	21.0	FC38C	1125	36.0	26.8	15.75	13.00
TCHE36S4(3,4)S1	TL8E100C20UH11	21.0	FC38C	1050	36.0	26.2	16.00	13.00
TCHE36S4(3,4)S1	TL9E060B12UH11	17.5	FC38C	1050	35.6	26.0	15.00	12.50
TCHE36S4(3,4)S1	TL9E080C16UH11	21.0	FC38C	1075	35.8	26.2	15.75	13.00
TCHE36S4(3,4)S1	TL9E100C20UH11	21.0	FC38C	1125	36.0	26.8	16.00	13.00
TCHE36S4(3,4)S1	TM8E080B12MP11	17.5	FC38C	1050	35.8	26.0	15.50	12.75
TCHE36S4(3,4)S1	TM8E080C16MP11	21.0	FC38C	1100	36.0	26.6	16.00	13.00
TCHE36S4(3,4)S1	TM8E080C20MP11	21.0	FC38C	1250	36.0	27.8	16.00	13.00
TCHE36S4(3,4)S1	TM8E100B12MP11	17.5	FC38C	1100	36.0	26.6	15.50	12.75
TCHE36S4(3,4)S1	TM8E100C16MP11	21.0	FC38C	1100	36.0	26.6	15.75	13.00
TCHE36S4(3,4)S1	TM8E100C20MP11	21.0	FC38C	1250	36.0	27.8	16.00	13.00
TCHE36S4(3,4)S1	TM8E120C16MP11	21.0	FC38C	1100	36.0	26.6	15.75	13.00
TCHE36S4(3,4)S1	TM8E120C20MP11	21.0	FC38C	1275	36.0	28.0	15.75	13.00
TCHE36S4(3,4)S1	TM8V080C16MP11C	21.0	FC38C	1200	35.6	27.0	15.10	12.50
TCHE36S4(3,4)S1	TM8V100C16MP11C	21.0	FC38C	1200	35.6	27.0	15.10	12.50
TCHE36S4(3,4)S1	TM8V100C20MP11C	21.0	FC38C	1150	35.8	26.8	15.50	13.00
TCHE36S4(3,4)S1	TM8V120C20MP11C	21.0	FC38C	1150	35.8	26.8	15.50	13.00
TCHE36S4(3,4)S1	TM8X080B12MP11	17.5	FC38C	975	35.4	25.0	15.50	13.00
TCHE36S4(3,4)S1	TM8X080C16MP11	21.0	FC38C	1200	35.8	27.2	15.50	12.75
TCHE36S4(3,4)S1	TM8X100C16MP11	21.0	FC38C	1200	35.8	27.2	15.50	12.75
TCHE36S4(3,4)S1	TM8X100C20MP11	21.0	FC38C	1200	35.6	27.0	15.25	12.75
TCHE36S4(3,4)S1	TM8X120C20MP11	21.0	FC38C	1200	35.6	27.0	15.25	12.75
TCHE36S4(3,4)S1	TM8Y080B12MP11	17.5	FC38C	975	35.4	25.0	15.50	13.00
TCHE36S4(3,4)S1	TM8Y080C16MP11	21.0	FC38C	1200	35.8	27.2	15.50	12.75
TCHE36S4(3,4)S1	TM8Y100C16MP11	21.0	FC38C	1200	35.8	27.2	15.50	12.75
TCHE36S4(3,4)S1	TM8Y100C20MP11	21.0	FC38C	1200	35.6	27.0	15.25	12.75
TCHE36S4(3,4)S1	TM8Y120C20MP11	21.0	FC38C	1200	35.6	27.0	15.25	12.75
TCHE36S4(3,4)S1	TM9E060B12MP11	17.5	FC38C	950	35.0	24.8	15.25	13.00
TCHE36S4(3,4)S1	TM9E060B12MP12	17.5	FC38C	1075	35.6	26.0	15.00	12.50
TCHE36S4(3,4)S1	TM9E080B12MP12	17.5	FC38C	1075	35.8	26.2	15.50	12.75
TCHE36S4(3,4)S1	TM9E080C16MP11	21.0	FC38C	975	35.4	25.0	15.75	13.00
TCHE36S4(3,4)S1	TM9E080C16MP12	21.0	FC38C	1075	35.8	26.2	15.75	13.00
TCHE36S4(3,4)S1	TM9E080C20MP12	21.0	FC38C	1225	36.0	27.6	16.00	13.00
TCHE36S4(3,4)S1	TM9E100C16MP11	21.0	FC38C	1200	35.6	27.0	15.25	12.75
TCHE36S4(3,4)S1	TM9E100C16MP12	21.0	FC38C	1075	36.0	26.4	15.75	13.00
TCHE36S4(3,4)S1	TM9E100C20MP11	21.0	FC38C	1200	35.6	27.0	15.25	12.75
TCHE36S4(3,4)S1	TM9E100C20MP12	21.0	FC38C	1200	36.0	27.4	16.00	13.00
TCHE36S4(3,4)S1	TM9V080C16MP11C	21.0	FC38C	1175	35.8	27.0	15.50	12.75
TCHE36S4(3,4)S1	TM9V100C16MP11C	21.0	FC38C	1175	35.8	27.0	15.50	12.75
TCHE36S4(3,4)S1	TM9V100C20MP11C	21.0	FC38C	1200	35.6	27.0	15.25	12.75
TCHE36S4(3,4)S1	TM9Y060B12MP11	17.5	FC38C	950	35.0	24.8	15.25	13.00
TCHE36S4(3,4)S1	TM9Y080C16MP11	21.0	FC38C	975	35.4	25.0	15.75	13.00
TCHE36S4(3,4)S1	TM9Y100C16MP11	21.0	FC38C	1200	35.6	27.0	15.25	12.75
TCHE36S4(3,4)S1	TM9Y100C20MP11	21.0	FC38C	1200	35.6	27.0	15.25	12.75
TCHE36S4(3,4)S1	TMLE080B12MP11	17.5	FC38C	1050	35.8	26.0	15.50	12.75
TCHE36S4(3,4)S1	TMLE080C16MP11	21.0	FC38C	1100	36.0	26.6	16.00	13.00
TCHE36S4(3,4)S1	TMLE080C20MP11	21.0	FC38C	1250	36.0	27.8	16.00	13.00
TCHE36S4(3,4)S1	TMLE100B12MP11	17.5	FC38C	1100	36.0	26.6	15.50	12.75
TCHE36S4(3,4)S1	TMLE100C16MP11	21.0	FC38C	1100	36.0	26.6	15.75	13.00
TCHE36S4(3,4)S1	TMLE100C20MP11	21.0	FC38C	1250	36.0	27.8	16.00	13.00
TCHE36S4(3,4)S1	TMLE120C16MP11	21.0	FC38C	1100	36.0	26.6	15.75	13.00
TCHE36S4(3,4)S1	TMLE120C20MP11	21.0	FC38C	1275	36.0	28.0	15.75	13.00

COOLING CAPACITY - With High Efficiency Motor Furnaces¹ (Continued)

UNIT MODEL	FURNACE		COIL MODEL ²	COOLING				
	MODEL	WIDTH		RATED CFM	NET MBH		SEER	EER
					TOTAL	SENS.		
TCHE36S4(3,4)S1	TMLV080C16MP11C	21.0	FC38C	1200	35.6	27.0	15.10	12.50
TCHE36S4(3,4)S1	TMLV100C16MP11C	21.0	FC38C	1200	35.6	27.0	15.10	12.50
TCHE36S4(3,4)S1	TMLV100C20MP11C	21.0	FC38C	1150	35.8	26.8	15.50	13.00
TCHE36S4(3,4)S1	TMLV120C20MP11C	21.0	FC38C	1150	35.8	26.8	15.50	13.00
TCHE36S4(3,4)S1	TMLX080B12MP11	17.5	FC38C	975	35.4	25.0	15.50	13.00
TCHE36S4(3,4)S1	TMLX080C16MP11	21.0	FC38C	1200	35.8	27.2	15.50	12.75
TCHE36S4(3,4)S1	TMLX100C16MP11	21.0	FC38C	1200	35.8	27.2	15.50	12.75
TCHE36S4(3,4)S1	TMLX100C20MP11	21.0	FC38C	1200	35.6	27.0	15.25	12.75
TCHE36S4(3,4)S1	TMLX120C20MP11	21.0	FC38C	1200	35.6	27.0	15.25	12.75
TCHE36S4(3,4)S1	TP9C080C16MP12C	21.0	FC38C	1175	35.8	27.0	15.50	12.75
TCHE36S4(3,4)S1	TP9C100C16MP12C	21.0	FC38C	1175	35.8	27.0	15.50	12.75
TCHE36S4(3,4)S1	TP9C100C20MP12C	21.0	FC38C	1200	35.6	27.0	15.25	12.75
TCHE36S4(3,4)S1	TPLC080C16MP12C	21.0	FC38C	1200	35.6	27.0	15.10	12.50
TCHE36S4(3,4)S1	TPLC100C16MP12C	21.0	FC38C	1200	35.6	27.0	15.10	12.50
TCHE36S4(3,4)S1	TPLC100C20MP12C	21.0	FC38C	1150	35.8	26.8	15.50	13.00
TCHE36S4(3,4)S1	TPLC120C20MP12C	21.0	FC38C	1150	35.8	26.8	15.50	13.00
TCHE36S4(3,4)S1	YP9C080C16MP12C	21.0	FC38C	1175	35.8	27.0	15.50	12.75
TCHE36S4(3,4)S1	YP9C100C16MP12C	21.0	FC38C	1175	35.8	27.0	15.50	12.75
TCHE36S4(3,4)S1	YP9C100C20MP12C	21.0	FC38C	1200	35.6	27.0	15.25	12.75
TCHE36S4(3,4)S1	YPLC080C16MP12C	21.0	FC38C	1200	35.6	27.0	15.10	12.50
TCHE36S4(3,4)S1	YPLC100C16MP12C	21.0	FC38C	1200	35.6	27.0	15.10	12.50
TCHE36S4(3,4)S1	YPLC100C20MP12C	21.0	FC38C	1150	35.8	26.8	15.50	13.00
TCHE36S4(3,4)S1	YPLC120C20MP12C	21.0	FC38C	1150	35.8	26.8	15.50	13.00
TCHE48S4(3,4)S1	TL8E080C16UH11	21.0	FC49D	1250	45.5	32.6	15.00	12.25
TCHE48S4(3,4)S1	TL8E100C20UH11	21.0	FC49D	1225	45.5	32.4	15.25	12.50
TCHE48S4(3,4)S1	TL9E080C16UH11	21.0	FC49D	1225	45.5	32.4	14.75	12.25
TCHE48S4(3,4)S1	TL9E100C20UH11	21.0	FC49D	1400	46.5	34.6	15.00	12.25
TCHE48S4(3,4)S1	TM8E080C16MP11	21.0	FC49D	1250	45.5	32.6	15.00	12.25
TCHE48S4(3,4)S1	TM8E080C20MP11	21.0	FC49D	1225	45.5	32.4	15.00	12.50
TCHE48S4(3,4)S1	TM8E100C16MP11	21.0	FC49D	1275	46.0	33.2	14.75	12.25
TCHE48S4(3,4)S1	TM8E100C20MP11	21.0	FC49D	1225	45.5	32.4	15.00	12.50
TCHE48S4(3,4)S1	TM8E120C16MP11	21.0	FC49D	1275	46.0	33.2	15.00	12.25
TCHE48S4(3,4)S1	TM8E120C20MP11	21.0	FC49D	1250	45.5	32.6	15.00	12.50
TCHE48S4(3,4)S1	TM8E130D20MP11	24.5	FC49D	1250	45.5	32.6	15.00	12.50
TCHE48S4(3,4)S1	TM8V080C16MP11C	21.0	FC49D	1425	46.0	34.4	14.25	12.00
TCHE48S4(3,4)S1	TM8V080C16MP12C	21.0	FC49D	1200	45.5	32.2	14.75	12.25
TCHE48S4(3,4)S1	TM8V100C16MP11C	21.0	FC49D	1425	46.0	34.4	14.25	12.00
TCHE48S4(3,4)S1	TM8V100C16MP12C	21.0	FC49D	1200	45.5	32.2	14.75	12.25
TCHE48S4(3,4)S1	TM8V100C20MP11C	21.0	FC49D	1425	46.0	34.2	15.00	12.50
TCHE48S4(3,4)S1	TM8V100C20MP12C	21.0	FC49D	1225	45.5	32.4	15.00	12.50
TCHE48S4(3,4)S1	TM8V120C20MP11C	21.0	FC49D	1425	46.0	34.2	15.00	12.50
TCHE48S4(3,4)S1	TM8V120C20MP12C	21.0	FC49D	1225	45.5	32.4	15.00	12.50
TCHE48S4(3,4)S1	TM8X080C16MP11	21.0	FC49D	1400	46.0	34.0	14.75	12.25
TCHE48S4(3,4)S1	TM8X100C16MP11	21.0	FC49D	1400	46.0	34.0	14.75	12.25
TCHE48S4(3,4)S1	TM8X100C20MP11	21.0	FC49D	1425	46.5	34.6	15.10	12.50
TCHE48S4(3,4)S1	TM8X120C20MP11	21.0	FC49D	1425	46.5	34.6	15.10	12.50
TCHE48S4(3,4)S1	TM8Y080C16MP11	21.0	FC49D	1400	46.0	34.0	14.75	12.25
TCHE48S4(3,4)S1	TM8Y100C16MP11	21.0	FC49D	1400	46.0	34.0	14.75	12.25
TCHE48S4(3,4)S1	TM8Y100C20MP11	21.0	FC49D	1425	46.5	34.6	15.10	12.50
TCHE48S4(3,4)S1	TM8Y120C20MP11	21.0	FC49D	1425	46.5	34.6	15.10	12.50
TCHE48S4(3,4)S1	TM9E080C16MP12	21.0	FC49D	1250	45.5	32.6	14.75	12.25
TCHE48S4(3,4)S1	TM9E080C20MP12	21.0	FC49D	1200	45.5	32.0	15.00	12.50

COOLING CAPACITY - With High Efficiency Motor Furnaces¹ (Continued)

UNIT MODEL	FURNACE		COIL MODEL ²	COOLING				
	MODEL	WIDTH		RATED CFM	NET MBH		SEER	EER
					TOTAL	SENS.		
TCHE48S4(3,4)S1	TM9E100C16MP11	21.0	FC49D	1425	46.0	34.4	14.25	11.75
TCHE48S4(3,4)S1	TM9E100C16MP12	21.0	FC49D	1250	45.5	32.6	14.75	12.25
TCHE48S4(3,4)S1	TM9E100C20MP11	21.0	FC49D	1400	46.0	34.0	15.00	12.50
TCHE48S4(3,4)S1	TM9E100C20MP12	21.0	FC49D	1400	46.5	34.6	15.00	12.50
TCHE48S4(3,4)S1	TM9E120D20MP11	24.5	FC49D	1400	46.5	34.4	15.10	12.50
TCHE48S4(3,4)S1	TM9E120D20MP12	24.5	FC49D	1200	45.5	32.0	15.00	12.50
TCHE48S4(3,4)S1	TM9V080C16MP12C	21.0	FC49D	1300	45.5	32.8	14.50	12.00
TCHE48S4(3,4)S1	TM9V100C16MP12C	21.0	FC49D	1175	45.5	32.0	15.00	12.50
TCHE48S4(3,4)S1	TM9V100C20MP11C	21.0	FC49D	1350	46.0	33.6	14.75	12.25
TCHE48S4(3,4)S1	TM9V100C20MP12C	21.0	FC49D	1225	45.5	32.4	14.75	12.25
TCHE48S4(3,4)S1	TM9V120D20MP11C	24.5	FC49D	1375	46.0	33.8	15.10	12.50
TCHE48S4(3,4)S1	TM9V120D20MP12C	24.5	FC49D	1200	45.5	32.0	15.10	12.50
TCHE48S4(3,4)S1	TM9Y100C16MP11	21.0	FC49D	1425	46.0	34.4	14.25	11.75
TCHE48S4(3,4)S1	TM9Y100C20MP11	21.0	FC49D	1400	46.0	34.0	15.00	12.50
TCHE48S4(3,4)S1	TM9Y120D20MP11	24.5	FC49D	1400	46.5	34.4	15.10	12.50
TCHE48S4(3,4)S1	TMLE080C16MP11	21.0	FC49D	1250	45.5	32.6	15.00	12.25
TCHE48S4(3,4)S1	TMLE080C20MP11	21.0	FC49D	1225	45.5	32.4	15.00	12.50
TCHE48S4(3,4)S1	TMLE100C16MP11	21.0	FC49D	1275	46.0	33.2	14.75	12.25
TCHE48S4(3,4)S1	TMLE100C20MP11	21.0	FC49D	1225	45.5	32.4	15.00	12.50
TCHE48S4(3,4)S1	TMLE120C16MP11	21.0	FC49D	1275	46.0	33.2	15.00	12.25
TCHE48S4(3,4)S1	TMLE120C20MP11	21.0	FC49D	1250	45.5	32.6	15.00	12.50
TCHE48S4(3,4)S1	TMLE130D20MP11	24.5	FC49D	1250	45.5	32.6	15.00	12.50
TCHE48S4(3,4)S1	TMLV080C16MP11C	21.0	FC49D	1425	46.0	34.4	14.25	12.00
TCHE48S4(3,4)S1	TMLV080C16MP12C	21.0	FC49D	1200	45.5	32.2	14.75	12.25
TCHE48S4(3,4)S1	TMLV100C16MP11C	21.0	FC49D	1425	46.0	34.4	14.25	12.00
TCHE48S4(3,4)S1	TMLV100C16MP12C	21.0	FC49D	1200	45.5	32.2	14.75	12.25
TCHE48S4(3,4)S1	TMLV100C20MP11C	21.0	FC49D	1425	46.0	34.2	15.00	12.50
TCHE48S4(3,4)S1	TMLV100C20MP12C	21.0	FC49D	1225	45.5	32.4	15.00	12.50
TCHE48S4(3,4)S1	TMLV120C20MP11C	21.0	FC49D	1425	46.0	34.2	15.00	12.50
TCHE48S4(3,4)S1	TMLV120C20MP12C	21.0	FC49D	1225	45.5	32.4	15.00	12.50
TCHE48S4(3,4)S1	TMLX080C16MP11	21.0	FC49D	1400	46.0	34.0	14.75	12.25
TCHE48S4(3,4)S1	TMLX100C16MP11	21.0	FC49D	1400	46.0	34.0	14.75	12.25
TCHE48S4(3,4)S1	TMLX100C20MP11	21.0	FC49D	1425	46.5	34.6	15.10	12.50
TCHE48S4(3,4)S1	TMLX120C20MP11	21.0	FC49D	1425	46.5	34.6	15.10	12.50
TCHE48S4(3,4)S1	TP9C080C16MP13C	21.0	FC49D	1300	45.5	32.8	14.50	12.00
TCHE48S4(3,4)S1	TP9C100C16MP13C	21.0	FC49D	1175	45.5	32.0	15.00	12.50
TCHE48S4(3,4)S1	TP9C100C20MP12C	21.0	FC49D	1350	46.0	33.6	14.75	12.25
TCHE48S4(3,4)S1	TP9C100C20MP13C	21.0	FC49D	1225	45.5	32.4	14.75	12.25
TCHE48S4(3,4)S1	TP9C120D20MP12C	24.5	FC49D	1375	46.0	33.8	15.10	12.50
TCHE48S4(3,4)S1	TP9C120D20MP13C	24.5	FC49D	1200	45.5	32.0	15.10	12.50
TCHE48S4(3,4)S1	TPLC080C16MP12C	21.0	FC49D	1425	46.0	34.4	14.25	12.00
TCHE48S4(3,4)S1	TPLC080C16MP13C	21.0	FC49D	1200	45.5	32.2	14.75	12.25
TCHE48S4(3,4)S1	TPLC100C16MP12C	21.0	FC49D	1425	46.0	34.4	14.25	12.00
TCHE48S4(3,4)S1	TPLC100C16MP13C	21.0	FC49D	1200	45.5	32.2	14.75	12.25
TCHE48S4(3,4)S1	TPLC100C20MP12C	21.0	FC49D	1425	46.0	34.2	15.00	12.50
TCHE48S4(3,4)S1	TPLC100C20MP13C	21.0	FC49D	1225	45.5	32.4	15.00	12.50
TCHE48S4(3,4)S1	TPLC120C20MP12C	21.0	FC49D	1425	46.0	34.2	15.00	12.50
TCHE48S4(3,4)S1	TPLC120C20MP13C	21.0	FC49D	1225	45.5	32.4	15.00	12.50
TCHE48S4(3,4)S1	YP9C080C16MP13C	21.0	FC49D	1300	45.5	32.8	14.50	12.00
TCHE48S4(3,4)S1	YP9C100C16MP13C	21.0	FC49D	1175	45.5	32.0	15.00	12.50
TCHE48S4(3,4)S1	YP9C100C20MP12C	21.0	FC49D	1350	46.0	33.6	14.75	12.25
TCHE48S4(3,4)S1	YP9C100C20MP13C	21.0	FC49D	1225	45.5	32.4	14.75	12.25
TCHE48S4(3,4)S1	YP9C120D20MP12C	24.5	FC49D	1375	46.0	33.8	15.10	12.50

COOLING CAPACITY - With High Efficiency Motor Furnaces¹ (Continued)

UNIT MODEL	FURNACE		COIL MODEL ²	COOLING				
	MODEL	WIDTH		RATED CFM	NET MBH		SEER	EER
					TOTAL	SENS.		
TCHE48S4(3,4)S1	YP9C120D20MP13C	24.5	FC49D	1200	45.5	32.0	15.10	12.50
TCHE48S4(3,4)S1	YPLC080C16MP12C	21.0	FC49D	1425	46.0	34.4	14.25	12.00
TCHE48S4(3,4)S1	YPLC080C16MP13C	21.0	FC49D	1200	45.5	32.2	14.75	12.25
TCHE48S4(3,4)S1	YPLC100C16MP12C	21.0	FC49D	1425	46.0	34.4	14.25	12.00
TCHE48S4(3,4)S1	YPLC100C16MP13C	21.0	FC49D	1200	45.5	32.2	14.75	12.25
TCHE48S4(3,4)S1	YPLC100C20MP12C	21.0	FC49D	1425	46.0	34.2	15.00	12.50
TCHE48S4(3,4)S1	YPLC100C20MP13C	21.0	FC49D	1225	45.5	32.4	15.00	12.50
TCHE48S4(3,4)S1	YPLC120C20MP12C	21.0	FC49D	1425	46.0	34.2	15.00	12.50
TCHE48S4(3,4)S1	YPLC120C20MP13C	21.0	FC49D	1225	45.5	32.4	15.00	12.50

For rated condition information, see the footnotes below the System Capacity - Single Piece and Modular Air Handlers table.

1. High Efficiency Motor Furnaces have B.O.D (Blower Off Delay) standard.
 2. CM coils available with a factory installed horizontal drain pan. See price pages for specific model number.
- PSC furnaces, such as the TG8S, TGLS, and TG9S, use Coil Only Ratings.

APPLICATIONS AND ACCESSORIES

Refer to Price Manual for specific model numbers.

Standard Application Limits*		
Maximum Lineset Equivalent Length	200 Ft	
Outdoor Ambient Temperature Limits		
Cooling Operation	Maximum DB	120°F
	Minimum DB	50°F

* For Low Ambient and/or Long Lineset Applications, please see the accessories listed below.

Non-Standard Lineset Applications - For installations with reduced diameter or long linesets, refer to the current version of the Piping Application Guide P/N 247077, available in the Application Bulletins section on www.simplygettingthejobdone.com.

OD Unit Anti Short Cycle Kit (10 Pack) S1-2TD08700124BK: A time delay that prevents rapid compressor restarting as a result of power interruption, limit switch operation, or thermostat resetting. Not required for HP models, or for AC models with factory electronic controls.

Standard Low Ambient Control Kit S1-2LA06700424: Allows the use of air conditioning at low outdoor ambient temperatures down to +20°F (-7°C). For use with all R-410A single stage AC & HP models.

Advanced Low Ambient Control Kit S1-2LA04701024: Contains the necessary components and controls to allow cooling operation down to -20°F (-29°C). For use with some R-410A single stage AC & HP models. This accessory can only be applied to models that contain a PSC outdoor fan motor.

Low Pressure Switch Kit S1-2PS06700524: Provides field installed low pressure (loss of charge) protection. Not required for HP models, or for AC models with factory electronic controls.

High Ambient Outdoor Fan Motor S1-FHM**HT:** Class F 70°C motor to allow cooling operation up to 160°F air entering the outdoor coil. For use with all R-410A single stage AC & HP models containing R-410A refrigerant only.

SOUND POWER RATINGS

Model Number	Octave Band Sound Power Level (db re. 1-pW)								
	63	125	250	500	1000	2000	4000	8000	dBA
TCHE36S4(3,4)S11	74	77	68	67	66	61	58	58	71
TCHE48S4(3,4)S11	75	81	70	68	66	61	58	58	72

Rated in accordance with ARI Standard 270.

Outdoor Communicating Board Kit (S1-33102952310): Electronic control upgrade for standard AC units to provide compatibility with the Residential Touch Screen Communicating Control.

Compressor Crankcase Heater Kit (S1-025-**-***):** A wrap-around electrical resistance heater that warms the compressor sump, reducing the chance of liquid slugging on startup. Required on all long lineset and low ambient applications. See Price Pages or Source1 SmartSearch for the correct part for each application.

Indoor TXV Kit S1-1TVM**:** Thermal expansion valves precisely meter refrigerant for optimum performance over a wide range of conditions. See System Charge Table, Price Pages, or Source1 Smart Search for TXV part number for each AC & HP model.

Cold Weather Charging Tent S1-CHGTENT01: Provides warm environment to accurately service AC & HP systems in ambient conditions 55°F (13°C) or colder.

Touch-up Paint S1-5130153**:** Color matched aerosol paint for touching up unit chassis and panels. See Price Pages or Source1 SmartSearch for the correct color for each application.

Compressor Sound Blanket S1-0100764*000: A field installed dense foam cover that provides 2dBA sound level reduction. See Price Pages or Source1 SmartSearch for the correct blanket for each application.

Thermostat: Compatible thermostat controls are available through accessory sourcing. For optimum performance, these outdoor units are fully compatible with our York Hx™ Touch-screen Thermostats available through Source1. For more information, see the thermostat section of the Product Equipment Catalog.

MECHANICAL SPECIFICATIONS

MANUFACTURE AND CERTIFICATIONS

- Units shall be manufactured in an ISO 9001 certified facility.
- Units shall be certified by CSA to UL 1995 / CSA 22.2 and performance certified to ANSI/AHRI Standard 210/240.
- Units shall be sound tested according to ANSI/AHRI Standard 270.
- Certified matched system ratings will be available for download from the AHRI online directory at www.ahridirectory.org
- Unit packaging shall be marked, "Assembled in the USA"

UNIT APPLICATION

- Units shall be approved for cooling operation between 50°F and 120°F without modification.
- Units shall be approved for linesets up to 200 feet equivalent length without modification.
- Units shall be approved for installation within 6 inches of a flat vertical wall without modification, according to the instructions in the technical literature.
- Units shall be certified for seismic applications in accordance with CBC 2007 and IBC 2006.
- Units shall be designed to 72dBA or less to minimize sound pollution.

UNIT ACCESS

- Units shall have a fan guard that can be removed independently of the cabinet for access to the condenser coil.
- Units shall have blow-through airflow for the condensing coil.
- Units shall have a separate compartment for electrical controls that can be accessed without disturbing the unit airflow.

UNIT CONSTRUCTION

- Units shall be shipped completely wired, piped and assembled. Wiring pigtails shall be provided for field control wiring connections. Service valves shall be provided for field refrigerant line connections.
- Units shall be factory leak checked, run tested, and shipped with a holding charge of R-410A refrigerant.
- Unit cabinet components shall be G90 equivalent steel finished with powder-coat paint rated at a minimum of 1,000 hours under ASTM B117 testing.
- Unit base pan shall be stamped G90 equivalent steel finished with powder-coat paint rated at a minimum of 1,000 hours under ASTM B117 testing.
- Units shall have a factory installed filter drier for faster installation and improved system reliability.
- Units shall be constructed with a high pressure switch and a low pressure switch for system protection.

UNIT COMPONENTS

- Compressor shall be hermetic with internal electrical overload protection and internal overpressure protection.
- Compressor shall be mounted on rubber vibration isolators that do not require the removal of transportation clips or brackets.
- Units shall be constructed with scroll compressors.
- Outdoor fan shall be direct drive with horizontal air discharge.
- Outdoor fan shall be direct drive with swept-wing blades for low sound levels.
- Outdoor coil shall be air cooled and constructed of zinc-coated aluminum microchannel construction for small size and low weight.

UNIT WARRANTIES

- Unit manufacturer shall provide a 10-Year compressor warranty without a requirement for unit registration.
- Unit manufacturer shall provide a 5-Year parts warranty without a requirement for unit registration.

TYPICAL INSTALLATION

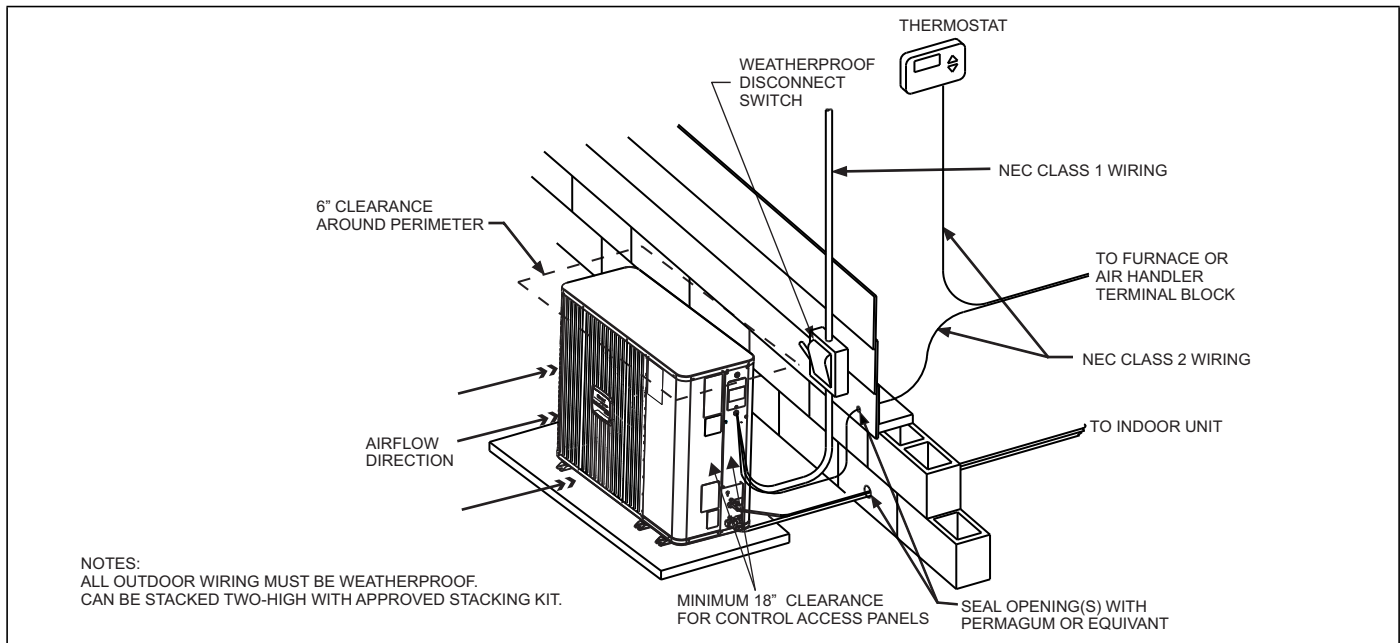

MOUNTING HOLE GRAPHIC

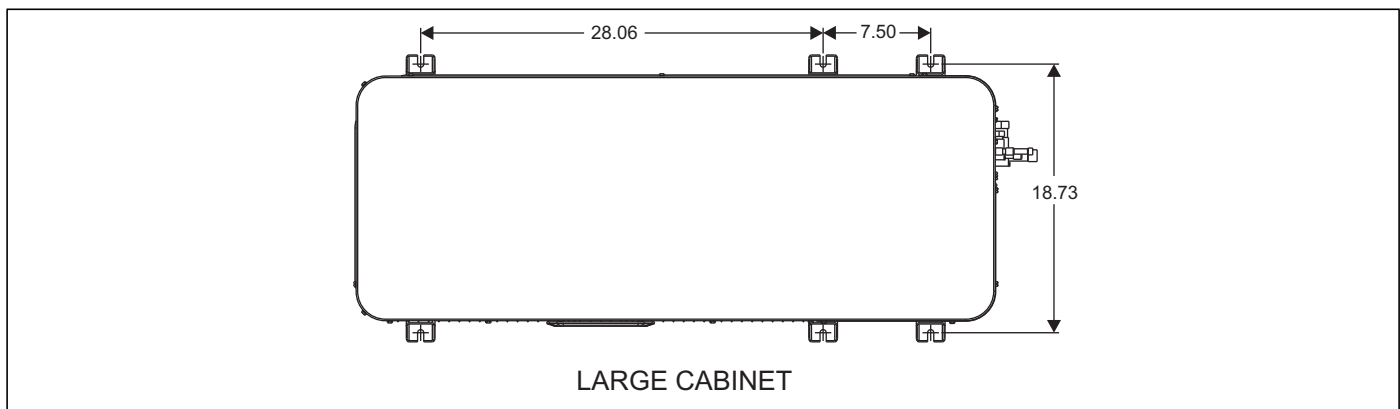

TYPICAL FIELD WIRING

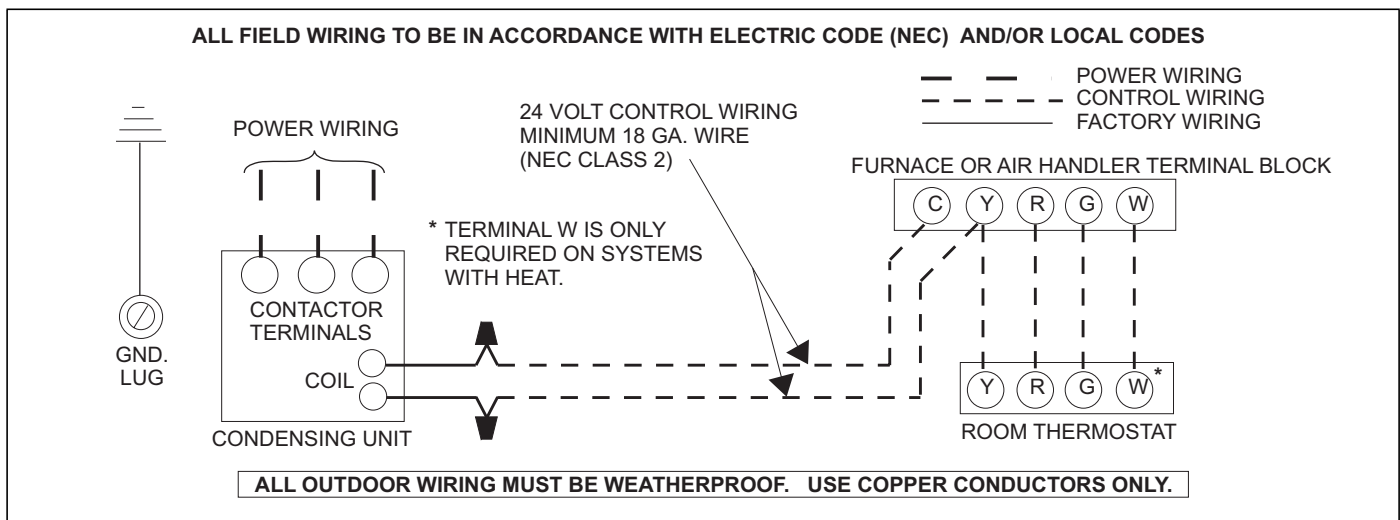

PERFORMANCE DATA - 3 TON

CONDENSER-ONLY DATA (OUTDOOR UNIT)																		
MODEL	SATURATED SUCTION @ COMPRESSOR		Outdoor Ambient Temperature															
			55 °F		65 °F		75 °F		85 °F		95 °F		105 °F		115 °F		120 °F	
	T (°F)	P (PSIG)	MBH	KW	MBH	KW	MBH	KW	MBH	KW	MBH	KW	MBH	KW	MBH	KW	MBH	KW
TCHE36S4(3,4)S1	35	107	33.3	3.24	31.8	3.24	30.2	3.24	28.6	3.24	26.9	3.24	25.0	3.24	23.0	3.24	21.9	3.24
	40	118	36.6	3.22	35.0	3.22	33.3	3.22	31.6	3.22	29.7	3.22	27.7	3.22	25.5	3.22	24.4	3.22
	45	130	40.1	3.20	38.4	3.20	36.7	3.20	34.8	3.20	32.8	3.20	30.6	3.20	28.3	3.20	27.0	3.20
	50	142	43.9	3.18	42.1	3.18	40.2	3.18	38.2	3.18	36.0	3.18	33.7	3.18	31.2	3.18	29.8	3.18
	55	156	47.8	3.09	45.9	3.16	43.9	3.16	41.8	3.16	39.4	3.16	36.9	3.16	34.3	3.16	32.9	3.16

Notes:

- For Outdoor Unit (Condenser) performance only. Data does not include the effects of air handler power or heat.
- Performance based on 15°F subcooling and 15°F superheat at the Outdoor Unit base valves.
 - Increase capacity by 1% for each 2°F increase in subcooling.
 - Decrease capacity by 1% for each 2°F decrease in subcooling.
- Maximum recommended condensing temperature is 140°F.

COOLING PERFORMANCE DATA																
AIR CONDITIONER MODEL NO.		TCHE36S4(3,4)S1														
INDOOR COIL MODEL NO.		FC38C														
AIR TEMP. ENTERING OUTDOOR UNIT (°F)	IDCFM	800					1000					1200				
	ID DB (°F)	80	80	75	80	80	80	80	75	80	80	80	80	75	80	80
	ID WB (°F)	57	62	62	67	72	57	62	62	67	72	57	62	62	67	72
55 / 45	T.C.	34.1	37.0	36.9	39.8	42.1	35.6	38.0	37.9	40.9	42.9	37.1	39.0	38.9	41.9	43.6
	S.C.	32.9	31.6	27.0	26.5	21.1	34.3	34.3	29.0	28.3	22.0	35.7	37.0	31.1	30.1	22.8
	K.W.	1.89	1.91	1.88	1.90	1.92	1.96	1.98	1.96	1.98	2.00	2.04	2.06	2.05	2.06	2.09
65 / 55	T.C.	33.2	35.7	35.7	38.7	41.4	34.7	36.8	36.7	39.7	42.2	36.2	37.9	37.7	40.7	43.0
	S.C.	32.0	30.9	26.6	26.3	21.0	33.4	33.6	28.8	28.3	22.1	34.9	36.2	31.0	30.4	23.2
	K.W.	2.07	2.09	2.07	2.08	2.08	2.15	2.16	2.14	2.15	2.16	2.22	2.23	2.22	2.23	2.25
75 / 63	T.C.	32.3	34.5	34.6	37.6	40.7	33.8	35.6	35.6	38.6	41.6	35.3	36.8	36.5	39.6	42.4
	S.C.	31.1	30.3	26.2	26.1	21.0	32.5	32.9	28.5	28.4	22.3	34.0	35.4	30.9	30.6	23.5
	K.W.	2.25	2.28	2.26	2.26	2.24	2.33	2.35	2.32	2.33	2.32	2.40	2.41	2.39	2.40	2.40
85 / 69	T.C.	31.4	33.4	33.2	36.3	39.3	32.8	34.5	34.1	37.2	40.1	34.3	35.7	35.0	38.1	40.9
	S.C.	30.2	29.9	25.5	25.5	20.5	31.6	32.1	27.9	27.9	21.9	33.0	34.4	30.3	30.2	23.3
	K.W.	2.49	2.54	2.52	2.51	2.49	2.56	2.60	2.58	2.58	2.57	2.63	2.67	2.64	2.65	2.64
95 / 75	T.C.	30.5	32.4	31.8	35.0	38.0	31.9	33.5	32.6	35.8	38.7	33.3	34.5	33.4	36.6	39.5
	S.C.	29.4	29.6	24.9	25.0	20.0	30.7	31.4	27.3	27.4	21.5	32.0	33.3	29.7	29.8	23.0
	K.W.	2.73	2.79	2.77	2.76	2.74	2.80	2.85	2.84	2.83	2.81	2.87	2.92	2.90	2.90	2.88
105 / 83	T.C.	29.2	30.8	30.1	33.2	36.2	30.6	32.0	30.9	34.0	36.9	31.9	33.2	31.7	34.8	37.6
	S.C.	28.2	28.6	24.2	24.3	19.4	29.4	30.3	26.5	26.7	20.9	30.7	32.0	28.9	29.1	22.4
	K.W.	3.16	3.20	3.20	3.14	3.08	3.19	3.23	3.25	3.19	3.15	3.22	3.26	3.29	3.24	3.22
115 / 89	T.C.	28.0	29.3	28.5	31.5	34.5	29.3	30.6	29.2	32.3	35.1	30.6	31.9	30.0	33.0	35.8
	S.C.	26.9	27.7	23.4	23.7	18.7	28.2	29.2	25.7	26.0	20.3	29.5	30.7	28.1	28.4	21.8
	K.W.	3.58	3.59	3.62	3.50	3.41	3.57	3.59	3.65	3.54	3.48	3.56	3.59	3.67	3.58	3.55
120 / 95	T.C.	26.7	27.9	26.9	29.8	32.7	28.0	29.2	27.6	30.5	33.3	29.3	30.6	28.3	31.2	34.0
	S.C.	25.7	26.8	22.7	23.0	18.1	27.0	28.1	25.0	25.4	19.7	28.2	29.4	27.2	27.7	21.2
	K.W.	3.99	3.99	4.04	3.86	3.75	3.94	3.96	4.04	3.89	3.81	3.90	3.92	4.05	3.92	3.87

NOTE: ALL CAPACITIES INCLUDE INDOOR FAN HEAT. KW VALUES ARE FOR THE SYSTEM (OUTDOOR + INDOOR).

Green shaded cells are ACCA (TVA) conditions.

Blue shaded cells are AHRI conditions.

Multipliers for determining the performance with other indoor sections.

NOTE: For dry bulb temperatures different than those listed (between 73-87 °F), sensible capacity increases by 1060 BTUH per 1000 CFM per degree above the listed temperature and decreases by 1060 BTUH per 1000 CFM per degree below the listed temperature.

COIL MULTIPLIERS - 3 TON

Air Handler	Coil	T.C.	S.C.	KW
-	FC38C	1.00	1.00	1.00
ME16CN21	FC38C	1.01	0.99	0.95
ME12CN41	FC38C	1.00	1.04	0.98
ME16CN41	FC38C	1.00	0.98	0.98
MVC16CN21	FC38C	1.01	0.99	0.96

FURNACE MULTIPLIERS - 3 TON

Furnaces	Coil	T.C.	S.C.	KW
TM9E080C16MP11	FC38C	0.99	0.91	0.96
TM9E080C16MP12	FC38C	1.00	0.96	0.97
TM9E080C20MP12	FC38C	1.01	1.01	0.98
TM9E100C16MP11	FC38C	0.99	0.99	0.99
TM9E100C16MP12	FC38C	1.01	0.96	0.98
TM9E100C20MP11	FC38C	0.99	0.99	0.99
TM9E100C20MP12	FC38C	1.01	1.00	0.98
TM9V080C16MP11C	FC38C	1.00	0.99	0.99
TM9V100C16MP11C	FC38C	1.00	0.99	0.99
TM9V100C20MP11C	FC38C	0.99	0.99	0.99
TM9Y060B12MP11	FC38C	0.98	0.91	0.95
TM9Y080C16MP11	FC38C	0.99	0.91	0.96
TM9Y100C16MP11	FC38C	0.99	0.99	0.99
TM9Y100C20MP11	FC38C	0.99	0.99	0.99
TMLE080B12MP11	FC38C	1.00	0.95	0.99
TMLE080C16MP11	FC38C	1.01	0.97	0.98
TMLE080C20MP11	FC38C	1.01	1.01	0.98
TMLE100B12MP11	FC38C	1.01	0.97	1.00

FURNACE MULTIPLIERS - 3 TON (Continued)

Furnaces	Coil	T.C.	S.C.	KW
TMLE100C16MP11	FC38C	1.01	0.97	0.98
TMLE100C20MP11	FC38C	1.01	1.01	0.98
TMLE120C16MP11	FC38C	1.01	0.97	0.98
TMLE120C20MP11	FC38C	1.01	1.02	0.98
TMLV080C16MP11C	FC38C	0.99	0.99	1.01
TMLV100C16MP11C	FC38C	0.99	0.99	1.01
TMLV100C20MP11C	FC38C	1.00	0.98	0.97
TMLV120C20MP11C	FC38C	1.00	0.98	0.97
TMLX080B12MP11	FC38C	0.99	0.91	0.96
TMLX080C16MP11	FC38C	1.00	0.99	0.99
TMLX100C16MP11	FC38C	1.00	0.99	0.99
TMLX100C20MP11	FC38C	0.99	0.99	0.99
TMLX120C20MP11	FC38C	0.99	0.99	0.99
TP9C080C16MP12C	FC38C	1.00	0.99	0.99
TP9C100C16MP12C	FC38C	1.00	0.99	0.99
TP9C100C20MP12C	FC38C	0.99	0.99	0.99
TPLC080C16MP12C	FC38C	0.99	0.99	1.01
TPLC100C16MP12C	FC38C	0.99	0.99	1.01
TPLC100C20MP12C	FC38C	1.00	0.98	0.97
TPLC120C20MP12C	FC38C	1.00	0.98	0.97
YP9C080C16MP12C	FC38C	1.00	0.99	0.99
YP9C100C16MP12C	FC38C	1.00	0.99	0.99
YP9C100C20MP12C	FC38C	0.99	0.99	0.99
YPLC080C16MP12C	FC38C	0.99	0.99	1.01
YPLC100C16MP12C	FC38C	0.99	0.99	1.01
YPLC100C20MP12C	FC38C	1.00	0.98	0.97
YPLC120C20MP12C	FC38C	1.00	0.98	0.97

PERFORMANCE DATA - 4 TON

CONDENSER-ONLY DATA (OUTDOOR UNIT)																		
MODEL	SATURATED SUCTION @ COMPRESSOR		Outdoor Ambient Temperature															
			55 °F		65 °F		75 °F		85 °F		95 °F		105 °F		115 °F		120 °F	
	T (°F)	P (PSIG)	MBH	KW	MBH	KW	MBH	KW	MBH	KW	MBH	KW	MBH	KW	MBH	KW	MBH	KW
TCHE48S4(3,4)S1	35	107	45.1	4.13	42.9	4.22	40.7	4.22	38.5	4.22	36.2	4.22	33.7	4.22	31.1	4.22	29.8	4.22
	40	118	49.5	4.20	47.0	4.20	44.7	4.20	42.3	4.20	39.9	4.20	37.2	4.20	34.4	4.20	33.0	4.20
	45	130	54.0	4.17	51.5	3.99	48.9	4.17	46.4	4.17	43.8	4.17	40.9	4.17	37.9	4.17	36.4	4.17
	50	142	58.8	4.14	56.1	4.05	53.4	4.14	50.6	4.14	47.8	4.14	44.9	4.14	41.7	4.14	39.9	4.14
	55	156	64.1	4.10	61.1	4.01	58.2	4.10	55.1	4.10	52.1	4.10	49.0	4.10	28.8	4.10	43.8	4.10

Notes:

- For Outdoor Unit (Condenser) performance only. Data does not include the effects of air handler power or heat.
- Performance based on 15°F subcooling and 15°F superheat at the Outdoor Unit base valves.
 - Increase capacity by 1% for each 2°F increase in subcooling.
 - Decrease capacity by 1% for each 2°F decrease in subcooling.
- Maximum recommended condensing temperature is 140°F.

COOLING PERFORMANCE DATA																
AIR CONDITIONER MODEL NO.		TCHE48S4(3,4)S11														
INDOOR COIL MODEL NO.		FC49D														
AIR TEMP. ENTERING OUTDOOR UNIT (°F)	IDCFM	1225					1425					1625				
	ID DB (°F)	80	80	75	80	80	80	80	75	80	80	80	80	75	80	80
	ID WB (°F)	57	62	62	67	72	57	62	62	67	72	57	62	62	67	72
55 / 45	T.C.	44.7	47.2	46.9	48.4	50.4	46.0	48.1	47.7	49.1	51.3	47.2	49.1	48.6	49.8	52.2
	S.C.	43.4	38.7	33.4	30.8	25.5	44.6	40.6	34.8	31.9	26.3	45.8	42.4	36.1	32.9	27.0
	K.W.	2.46	2.48	2.48	2.50	2.55	2.54	2.56	2.56	2.58	2.64	2.62	2.64	2.64	2.67	2.73
65 / 55	T.C.	43.7	46.1	46.3	48.5	51.2	45.1	47.1	47.3	49.4	52.0	46.6	48.2	48.3	50.2	52.9
	S.C.	42.3	39.0	33.5	31.7	26.1	43.8	41.5	35.4	33.1	27.0	45.2	44.0	37.2	34.5	28.0
	K.W.	2.71	2.73	2.74	2.75	2.79	2.79	2.81	2.81	2.83	2.88	2.87	2.89	2.89	2.92	2.97
75 / 63	T.C.	42.6	45.0	45.7	48.7	51.9	44.3	46.2	46.9	49.6	52.8	46.0	47.3	48.1	50.6	53.6
	S.C.	41.3	39.2	33.5	32.6	26.6	42.9	42.4	35.9	34.4	27.8	44.6	45.5	38.3	36.1	29.0
	K.W.	2.97	2.99	3.00	3.01	3.03	3.05	3.06	3.07	3.09	3.12	3.12	3.14	3.13	3.17	3.20
85 / 69	T.C.	41.3	43.1	43.9	46.9	50.6	43.0	44.3	45.0	47.8	51.4	44.7	45.4	46.1	48.7	52.2
	S.C.	40.0	38.6	32.9	32.0	26.2	41.7	41.2	35.3	34.1	27.4	43.3	43.8	37.8	36.1	28.7
	K.W.	3.33	3.35	3.36	3.36	3.37	3.40	3.42	3.44	3.44	3.46	3.47	3.49	3.51	3.52	3.54
95 / 75	T.C.	40.0	41.3	42.0	45.1	49.2	41.6	42.3	43.1	46.0	50.0	43.3	43.4	44.2	46.9	50.9
	S.C.	38.8	37.9	32.2	31.5	25.7	40.4	40.0	34.7	33.8	27.1	42.0	42.1	37.3	36.1	28.5
	K.W.	3.68	3.71	3.73	3.71	3.72	3.75	3.78	3.81	3.79	3.80	3.82	3.85	3.89	3.86	3.89
105 / 83	T.C.	38.1	39.3	39.9	43.1	47.1	39.8	40.6	41.0	44.0	47.9	41.6	41.9	42.2	44.9	48.7
	S.C.	37.0	36.7	31.2	30.8	24.9	38.6	38.7	33.8	33.2	26.4	40.3	40.7	36.4	35.5	27.8
	K.W.	4.24	4.30	4.33	4.23	4.20	4.28	4.32	4.39	4.29	4.28	4.32	4.34	4.44	4.35	4.35
115 / 89	T.C.	36.4	37.3	37.9	41.2	45.1	38.1	38.9	39.0	42.0	45.9	39.9	40.5	40.1	42.9	46.7
	S.C.	35.2	35.5	30.3	30.1	24.2	36.9	37.4	32.9	32.5	25.7	38.6	39.3	35.6	35.0	27.2
	K.W.	4.78	4.86	4.91	4.73	4.67	4.79	4.83	4.94	4.78	4.74	4.80	4.81	4.97	4.83	4.81
120 / 95	T.C.	34.6	35.4	35.8	39.2	43.0	36.4	37.2	37.0	40.1	43.8	38.2	39.1	38.1	41.0	44.6
	S.C.	33.5	34.3	29.4	29.4	23.5	35.3	36.1	32.0	31.9	25.0	37.0	37.9	34.7	34.4	26.5
	K.W.	5.31	5.42	5.49	5.23	5.14	5.30	5.35	5.50	5.26	5.20	5.28	5.28	5.50	5.30	5.26
NOTE: ALL CAPACITIES INCLUDE INDOOR FAN HEAT. KW VALUES ARE FOR THE SYSTEM (OUTDOOR + INDOOR).																
NOTE: ALL CAPACITIES INCLUDE INDOOR FAN HEAT. KW VALUES ARE FOR THE SYSTEM (OUTDOOR + INDOOR).																
Green shaded cells are ACCA (TVA) conditions.																
Blue shaded cells are AHR1 conditions.																

Multipliers for determining the performance with other indoor sections.

NOTE: For dry bulb temperatures different than those listed (between 73-87 °F), sensible capacity increases by 1060 BTUH per 1000 CFM per degree above the listed temperature and decreases by 1060 BTUH per 1000 CFM per degree below the listed temperature.

COIL MULTIPLIERS - 4 TON

Air Handler	Coil	T.C.	S.C.	KW
-	FC49D	1.00	1.00	1.00
ME14DN21	FC49D	1.01	1.02	0.98
ME20DN21	FC49D	1.01	1.02	0.98
ME20DN41	FC49D	1.01	1.03	0.98
MVC14DN21	FC49D	0.99	0.94	0.94
MVC20DN21	FC49D	1.01	1.01	0.96

FURNACE MULTIPLIERS - 4 TON

Furnaces	Coil	T.C.	S.C.	KW
TL8E080C16UH11	FC49D	0.99	0.96	0.98
TL8E100C20UH11	FC49D	0.99	0.96	0.96
TL9E080C16UH11	FC49D	0.99	0.96	0.98
TL9E100C20UH11	FC49D	1.01	1.02	1.00
TM8E080C16MP11	FC49D	0.99	0.96	0.98
TM8E080C20MP11	FC49D	0.99	0.96	0.96
TM8E100C16MP11	FC49D	1.00	0.98	0.99
TM8E100C20MP11	FC49D	0.99	0.96	0.96
TM8E120C16MP11	FC49D	1.00	0.98	0.99
TM8E120C20MP11	FC49D	0.99	0.96	0.96
TM8E130D20MP11	FC49D	0.99	0.96	0.96
TM8V080C16MP11C	FC49D	1.00	1.02	1.01
TM8V080C16MP12C	FC49D	0.99	0.95	0.98
TM8V100C16MP11C	FC49D	1.00	1.02	1.01
TM8V100C16MP12C	FC49D	0.99	0.95	0.98
TM8V100C20MP11C	FC49D	1.00	1.01	0.97
TM8V100C20MP12C	FC49D	0.99	0.96	0.96
TM8V120C20MP11C	FC49D	1.00	1.01	0.97
TM8V120C20MP12C	FC49D	0.99	0.96	0.96
TM8X080C16MP11	FC49D	1.00	1.01	0.99
TM8X100C16MP11	FC49D	1.00	1.01	0.99
TM8X100C20MP11	FC49D	1.01	1.02	0.98
TM8X120C20MP11	FC49D	1.01	1.02	0.98
TM8Y080C16MP11	FC49D	1.00	1.01	0.99
TM8Y100C16MP11	FC49D	1.00	1.01	0.99
TM8Y100C20MP11	FC49D	1.01	1.02	0.98
TM8Y120C20MP11	FC49D	1.01	1.02	0.98
TM9E080C16MP12	FC49D	0.99	0.96	0.98
TM9E080C20MP12	FC49D	0.99	0.95	0.96
TM9E100C16MP11	FC49D	1.00	1.02	1.03
TM9E100C16MP12	FC49D	0.99	0.96	0.98
TM9E100C20MP11	FC49D	1.00	1.01	0.97
TM9E100C20MP12	FC49D	1.01	1.02	0.98
TM9E120D20MP11	FC49D	1.01	1.02	0.98
TM9E120D20MP12	FC49D	0.99	0.95	0.96
TM9V080C16MP12C	FC49D	0.99	0.97	1.00
TM9V100C16MP12C	FC49D	0.99	0.95	0.96
TM9V100C20MP11C	FC49D	1.00	0.99	0.99
TM9V100C20MP12C	FC49D	0.99	0.96	0.98
TM9V120D20MP11C	FC49D	1.00	1.00	0.97
TM9V120D20MP12C	FC49D	0.99	0.95	0.96

FURNACE MULTIPLIERS - 4 TON (Continued)

Furnaces	Coil	T.C.	S.C.	KW
TM9Y100C16MP11	FC49D	1.00	1.02	1.03
TM9Y100C20MP11	FC49D	1.00	1.01	0.97
TM9Y120D20MP11	FC49D	1.01	1.02	0.98
TMLE080C16MP11	FC49D	0.99	0.96	0.98
TMLE080C20MP11	FC49D	0.99	0.96	0.96
TMLE100C16MP11	FC49D	1.00	0.98	0.99
TMLE100C20MP11	FC49D	0.99	0.96	0.96
TMLE120C16MP11	FC49D	1.00	0.98	0.99
TMLE120C20MP11	FC49D	0.99	0.96	0.96
TMLE130D20MP11	FC49D	0.99	0.96	0.96
TMLV080C16MP11C	FC49D	1.00	1.02	1.01
TMLV080C16MP12C	FC49D	0.99	0.95	0.98
TMLV100C16MP11C	FC49D	1.00	1.02	1.01
TMLV100C16MP12C	FC49D	0.99	0.95	0.98
TMLV100C20MP11C	FC49D	1.00	1.01	0.97
TMLV100C20MP12C	FC49D	0.99	0.96	0.96
TMLV120C20MP11C	FC49D	1.00	1.01	0.97
TMLV120C20MP12C	FC49D	0.99	0.96	0.96
TMLX080C16MP11	FC49D	1.00	1.01	0.99
TMLX100C16MP11	FC49D	1.00	1.01	0.99
TMLX100C20MP11	FC49D	1.01	1.02	0.98
TMLX120C20MP11	FC49D	1.01	1.02	0.98
TP9C080C16MP13C	FC49D	0.99	0.97	1.00
TP9C100C16MP13C	FC49D	0.99	0.95	0.96
TP9C100C20MP12C	FC49D	1.00	0.99	0.99
TP9C100C20MP13C	FC49D	0.99	0.96	0.98
TP9C120D20MP12C	FC49D	1.00	1.00	0.97
TP9C120D20MP13C	FC49D	0.99	0.95	0.96
TPLC080C16MP12C	FC49D	1.00	1.02	1.01
TPLC080C16MP13C	FC49D	0.99	0.95	0.98
TPLC100C16MP12C	FC49D	1.00	1.02	1.01
TPLC100C16MP13C	FC49D	0.99	0.95	0.98
TPLC100C20MP12C	FC49D	1.00	1.01	0.97
TPLC100C20MP13C	FC49D	0.99	0.96	0.96
TPLC120C20MP12C	FC49D	1.00	1.01	0.97
TPLC120C20MP13C	FC49D	0.99	0.96	0.96
YP9C080C16MP13C	FC49D	0.99	0.97	1.00
YP9C100C16MP13C	FC49D	0.99	0.95	0.96
YP9C100C20MP12C	FC49D	1.00	0.99	0.99
YP9C100C20MP13C	FC49D	0.99	0.96	0.98
YP9C120D20MP12C	FC49D	1.00	1.00	0.97
YP9C120D20MP13C	FC49D	0.99	0.95	0.96
YPLC080C16MP12C	FC49D	1.00	1.02	1.01
YPLC080C16MP13C	FC49D	0.99	0.95	0.98
YPLC100C16MP12C	FC49D	1.00	1.02	1.01
YPLC100C16MP13C	FC49D	0.99	0.95	0.98
YPLC100C20MP12C	FC49D	1.00	1.01	0.97
YPLC100C20MP13C	FC49D	0.99	0.96	0.96
YPLC120C20MP12C	FC49D	1.00	1.01	0.97
YPLC120C20MP13C	FC49D	0.99	0.96	0.96