

# INSTALLATION MANUAL

## R-410A OUTDOOR SPLIT-SYSTEM HEAT PUMP

MODELS: 16 SEER -  
YHM, CH16, TH16 SERIES  
2 – 5 TONS (1 PHASE)



### LIST OF SECTIONS

GENERAL .....	1	SYSTEM START-UP .....	10
SAFETY .....	1	SYSTEM OPERATION .....	10
UNIT INSTALLATION .....	2	FAULT CODE - INVERTER TROUBLESHOOTING .....	14
INDOOR EXPANSION DEVICE .....	6	INSTRUCTING THE OWNER .....	26
EVACUATION .....	7	WIRING DIAGRAM .....	27
SYSTEM CHARGE .....	7	START UP SHEET .....	29
ELECTRICAL CONNECTIONS .....	9		

### LIST OF FIGURES

Typical Installation .....	3	Jumper Location for Charging Mode and Normal Operation Mode ..	8
Installation of Vapor Line .....	4	Outdoor Unit Control Box (Single Phase) .....	9
Underground Installation .....	4	Typical Field Wiring (Air Handler / Electrical Heat) (Single-Phase) ..	10
Heat Protection .....	5	Heat Pump Flow Diagram .....	11
TXV Installation .....	6	Heat Pump Main Control Board .....	11
TXV Bulb Installation .....	6	Defrost Operation Curves (Variables - Defrost Active Variable) ....	24
Proper Bulb Location .....	6	Wiring Diagram - Single Phase (Demand Defrost) .....	27
Vertical Temperature Bulb Orientation .....	7		

### LIST OF TABLES

Minimum / Maximum Operating Limit Conditions .....	2	Fault Code Display .....	13
Allowable Vertical Linesets .....	2	High Pressure Switch (HPS) Fault .....	14
R-410A Saturation Properties .....	8	Compressor Inverter Drive Fault .....	15
TEST Input Functionality with Y .....	10	Outdoor Fan Motor Fault .....	19
TEST Input Functionality without Y .....	11	Compressor Control Protection Fault .....	21
Status Code Display .....	12	Miscellaneous Fault Codes .....	23
Operational Mode Display .....	12		

## SECTION I: GENERAL

The outdoor units are designed to be connected to a matching indoor coil with sweat connect lines. Sweat connect units are factory charged with refrigerant for a nominal sized matching indoor coil plus 15 feet of field-supplied lines.

Matching indoor coils can be used with a thermostatic expansion valve (TXV). Refer to the Tabular Data Sheet or to the Technical Guide for the proper selection.

## SECTION II: SAFETY



This is a safety alert symbol. When you see this symbol on labels or in manuals, be alert to the potential for personal injury.

Understand and pay particular attention to the signal words **DANGER**, **WARNING**, or **CAUTION**.

**DANGER** indicates an **imminently** hazardous situation, which, if not avoided, **will result in death or serious injury**.

**WARNING** indicates a **potentially** hazardous situation, which, if not avoided, **could result in death or serious injury**.

**CAUTION** indicates a potentially hazardous situation, which, if not avoided **may result in minor or moderate injury**. It is also used to alert against unsafe practices and hazards involving only property damage.

## ⚠ WARNING

*Improper installation may create a condition where the operation of the product could cause personal injury or property damage. Improper installation, adjustment, alteration, service or maintenance can cause injury or property damage. Refer to this manual for assistance or for additional information, consult a qualified contractor, installer or service agency.*

## ⚠ CAUTION

*This product must be installed in strict compliance with the enclosed installation instructions and any applicable local, state, and national codes including, but not limited to building, electrical, and mechanical codes.*

## ⚠ CAUTION

*R-410A systems operate at higher pressures than R-22 systems. Do not use R-22 service equipment or components on R-410A equipment. Service equipment **Must Be Rated** for R-410A.*

**INSPECTION**

As soon as a unit is received, it should be inspected for possible damage during transit. If damage is evident, the extent of the damage should be noted on the carrier's delivery receipt. A separate request for inspection by the carrier's agent should be made in writing. See Local Distributor for more information.

**Requirements For Installing/Serviceing R-410A Equipment**

- Gauge sets, hoses, refrigerant containers, and recovery system must be designed to handle the POE type oils, and the higher pressures of R-410A.
- Manifold sets should be high side and low side with low side retard.
- All hoses must have a 700 psig service pressure rating.
- Leak detectors should be designed to detect HFC refrigerant.
- Recovery equipment (including refrigerant recovery containers) must be specifically designed to handle R-410A.
- Do not use an R-22 TXV.

**LIMITATIONS**

The unit should be installed in accordance with all National, State and Local Safety Codes and the limitations listed below:

1. Limitations for the indoor unit, coil, and appropriate accessories must also be observed.
2. The outdoor unit must not be installed with any duct work in the air stream. The outdoor fan is the propeller type and is not designed to operate against any additional external static pressure.
3. The maximum and minimum conditions for operation must be observed to ensure a system that will give maximum performance with minimal service.

**TABLE 1:** Minimum / Maximum Operating Limit Conditions

AIR TEMPERATURE AT OUTDOOR COIL, ° F (° C)				AIR TEMPERATURE AT INDOOR COIL, ° F (° C)			
Min.		Max.		Min.		Max.	
DB Cool	DB Heat	DB Cool	DB Heat	WB Cool	DB Heat	WB Cool	DB Heat
35(2)*	-20(-29)	125(52)*	75(24)	57(14)	50(10)	72(22)	80(27)
*Reference the NOTICE under the "Unit Reduced Capacity Conditions" section.							

4. The maximum allowable equivalent line length for this product is 80 feet.

**Standard Lineset Applications**

Maximum allowable lineset varies depending on the vertical separation between the evaporator and condenser. See Table 2 for allowable line set lengths and sizing.

**TABLE 2:** Allowable Vertical Linesets.

Model	Liquid Line	Suction Line	Max Line Length - Units on Equal Level	Max Suction Line Riser - If OD Unit is Above ID Unit	Max Liquid Line Riser - If OD Unit is Below ID Unit
24	3/8"	3/4"	80 feet	25 feet	25 feet
36		7/8"			
48					
60					

**Unit Reduced Capacity Conditions**

NOTICE

**Intelligence Power Module (IPM) Temperature Protection:**  
*If excessive (IPM) inverter temperatures are sensed, the compressor speed / capacity is reduced every 60 seconds until an acceptable condition is reached.*  
*When the inverter temperature returns to an acceptable level, the system returns to normal operation.*

**Over / Under Current Protection:** *If a low or high Current Condition is sensed, the compressor speed / capacity is reduced every 30 seconds until an acceptable current level is reached.*  
*When the system reaches an acceptable current level, the compressor and fan return to normal operating conditions.*

**Over / Under Voltage Protection:** *If a low or high supply Voltage Condition is experienced (below 197 VAC or above 252 VAC), the compressor speed / capacity is automatically reduced every 15 seconds until an acceptable voltage level is sensed.*  
*When an acceptable voltage level is sensed, the system automatically returns to a normal state of operation.*

**High Outdoor Ambient Temperature Protection:** *During high outdoor ambient temperature conditions above 109°F (43°C), the compressor speed reduces to protect the system. If the outdoor ambient temperature goes above 125 °F (52°C), the system goes into a soft-lockout condition halting operation for system protection. Consider these limitations when installing any of the heat pumps included in this document.*  
*When the system reaches acceptable operating conditions, the system returns to normal operation.*

**High Altitude Protection:** *If the unit is installed in Altitudes of 6,500 ft / 2,000 m above sea level or higher, the compressor and outdoor fan reduce speeds to protect the system. It is not recommended these units be installed at altitudes greater than 6,500 ft / 2,000 m above sea level.*

**Low Ambient Protection:**  
**Cooling mode:** *The unit automatically adjusts to maintain cooling operation in outdoor ambient conditions down to 35° F (2° C). The unit reduces capacity and or cycles off if asked to provide cooling when the outdoor temperature is at or below these conditions.*  
**Heating Mode:** *The unit provides compressor heat down to an outdoor ambient temperature of -20° F (-29° C). As the outdoor ambient temperature reduces, available heat reduces for all air source heat pumps. Make sure the balance point and auxiliary heat are appropriately set and sized for the application of the heat pump.*

**SECTION III: UNIT INSTALLATION**

**LOCATION**

Before starting the installation, select and check the suitability of the location for both the indoor and outdoor unit. Observe all limitations and clearance requirements.

The outdoor unit must have sufficient clearance for air entrance to the condenser coil, air discharge, and service access. See Figure 1.

NOTICE

*For multiple unit installations, units must be spaced a minimum of 24" (61 cm) apart (coil face to coil face).*

If the unit is to be installed on a hot sun exposed roof or a paved ground area that is seasonally hot, the unit should be raised sufficiently above the roof or ground to avoid taking the accumulated layer of hot air into the outdoor unit (which can cause the unit to derate prematurely).

If the system is being installed during seasonally cold weather of 55°F or below, the preferred method is to weigh in the charge. For charging or checking the system charge at 55°F or below, refer to the "Optional Cold Weather Charging" procedures near the end of SECTION VI: SYSTEM CHARGE. There is an "Optional Cold Weather Charging" accessory kit to prevent the outdoor unit from taking in cold air below 55°F. The kit part number can be found in the list of accessory kits on the UPGNET web site.

Provide adequate structural support for the unit.

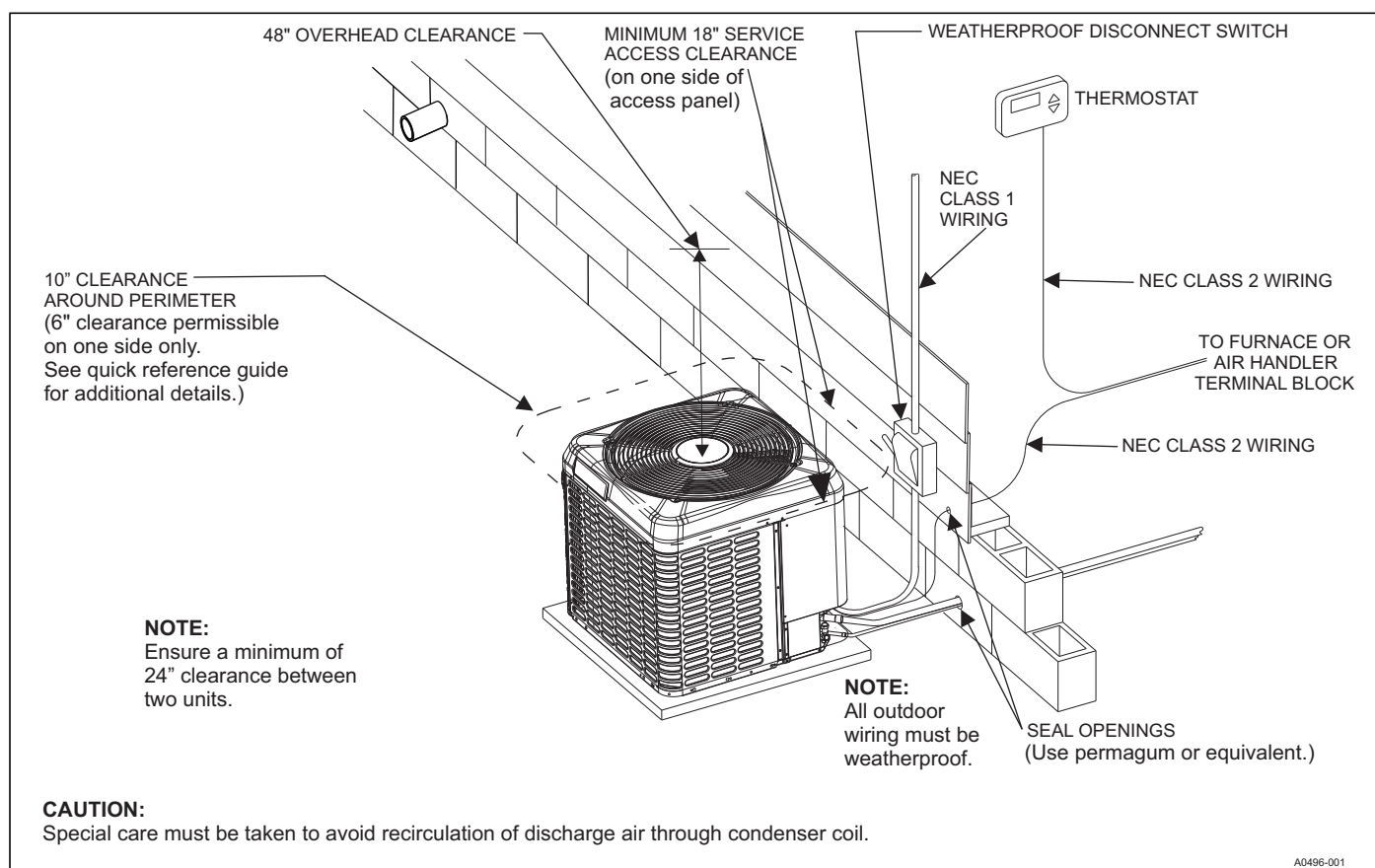

**FIGURE 1:** Typical Installation

### ADD-ON REPLACEMENT/RETROFIT

When this unit is being used as a replacement for an R-410A unit, it is required that the outdoor unit, indoor coil, and metering device all be replaced. The following steps should be performed in order to insure proper system operation and performance. Line-set change out is also recommended.

1. Change-out of the indoor coil to an approved R-410A coil / air handling unit combination with the appropriate metering device.
2. Change-out of the line-set when replacing an R-22 unit with an R410-A unit is highly recommended to reduce cross-contamination of oils and refrigerants.
3. If change-out of the line set is not practical, then the following precautions should be taken.
  - Inspect the line set for kinks, sharp bends, or other restrictions, and for corrosion.
  - Determine if there are any low spots which might be serving as oil traps.
  - Flush the line set with a commercially available flush kit to remove as much of the existing oil and contaminants as possible.
  - Install a suction line filter-drier to trap any remaining contaminants, and remove after 50 hours of operation.
4. If the outdoor unit is being replaced due to a compressor burnout, then installation of a 100% activated alumina suction-line filter drier in the suction-line is required, in addition to the factory installed bi-flow liquid-line drier. Operate the system for 10 hours. Monitor the suction drier pressure drop. If the pressure drop exceeds 3 psig, replace both the suction-line and liquid-line driers. After a total of 10 hours run time where the suction-line pressure drop has not exceeded 3 psig, replace the liquid line drier, and remove the suction-line drier. Never leave a suction-line drier in the system longer than 50 hours of run time.

### GROUND INSTALLATION

The unit may be installed at ground level on a solid base that will not shift or settle, causing strain on the refrigerant lines and possible leaks. The unit must be installed in as level a position as possible while maintaining the clearances shown in Figure 1.

Normal operating sound levels may be objectionable if the unit is placed directly under windows of certain rooms (bedrooms, study, etc.).

Condensate will drain from beneath the coil of the outdoor unit during the defrost cycle. Normally this condensate may be allowed to drain directly on the ground.

## ▲ WARNING

*The outdoor unit should not be installed in an area where mud or ice could cause personal injury. Remember that condensate will drip from the unit coil during heat and defrost cycles and that this condensate will freeze when the temperature of the outdoor air is below 32°F.*

Elevate the unit sufficiently to prevent any blockage of the air entrances by snow in areas where there will be snow accumulation. Check the local weather bureau for the expected snow accumulation in your area. Isolate the unit from rain gutters to avoid any possible wash out of the foundation.

### ROOF INSTALLATION

When installing units on a roof, the structure must be capable of supporting the total weight of the unit, including a pad, lintels, rails, etc., which should be used to minimize the transmission of sound or vibration into the conditioned space.

**WALL MOUNT INSTALLATION**

Care must be taken to mount the outdoor unit on a solid base that is sloped to shed water, secure from settlement, and is isolated from the structural foundation or walls to prevent sound and vibration transmission into the living space.

On occasion, site conditions may require direct wall mounted brackets to be used to locate and support the outdoor unit. In these applications, care must be taken to address unit base pan support, structural integrity, safe access and serviceability, as well as the possible sound and vibration transmission into the structure. These applications are best served by a properly engineered solution.

**UNIT PLACEMENT**

**NOTICE**

*Heat pumps will defrost periodically resulting in water drainage. The unit should not be located where water drainage may freeze and create a hazardous condition - such as sidewalks and steps.*

1. Provide a base in the pre-determined location.
2. Remove the shipping carton and inspect for possible damage.
3. Ensure that compressor tie-down bolts remain tightened.
4. Position the unit on the base provided.

**LIQUID LINE FILTER-DRIER**

The heat pumps have a solid core bi-flow filter/drier located in the liquid line.

**CAUTION**

*Failure to use the same as the original factory drier or using a substitute drier or a granular type may result in damage to the equipment.*

**NOTICE**

*Replacements for the liquid line drier must be exactly the same as marked on the original factory drier. See Source 1 for O.E.M. replacement driers.*

R-410A Filter-Drier Source 1 Part No.	Apply with Models
S1-52636219000	All

**PIPING CONNECTIONS**

The outdoor condensing unit must be connected to the indoor evaporator coil using field supplied refrigerant grade (ACR) copper tubing that is internally clean and dry. Units should be installed only with the tubing sizes for approved system combinations as specified in tabular data sheet. The charge given is applicable for total tubing lengths up to 15 feet (4.6 m).

**NOTICE**

*Using a larger than specified line size could result in oil return problems. Using too small a line will result in loss of capacity and other problems caused by insufficient refrigerant flow. For the heat pump, maintain level horizontal vapor lines between the indoor unit and the outdoor unit to facilitate proper oil return.*

**WARNING**

*Never install a suction-line filter drier in the liquid line of an R-410A system. Failure to follow this warning can cause a fire, injury or death.*

**CAUTION**

*This system uses R-410A refrigerant which operates at higher pressures than R-22. No other refrigerant may be used in this system. Gauge sets, hoses, refrigerant containers, and recovery system must be designed to handle R-410A. If you are unsure, consult the equipment manufacturer.*

**PRECAUTIONS DURING LINE INSTALLATION**

1. Install the lines with as few bends as possible. Care must be taken not to damage the couplings or kink the tubing. Use clean hard drawn copper tubing where no appreciable amount of bending around obstruction is necessary. If soft copper must be used, care must be taken to avoid sharp bends which may cause a restriction.
2. The lines should be installed so that they will not obstruct service access to the coil, air handling system, or filter.
3. Care must also be taken to isolate the refrigerant lines to minimize noise transmission from the equipment to the structure.
4. The vapor line must be insulated with a minimum of 1/2" foam rubber insulation (Armaflex or equivalent). Liquid lines that will be exposed to direct sunlight, high temperatures, or excessive humidity must also be insulated.
5. Tape and suspend the refrigerant lines as shown. DO NOT allow tube metal-to-metal contact. See Figure 2.
6. Use PVC piping as a conduit for all underground installations as shown in Figure 3. Buried lines should be kept as short as possible to minimize the build up of liquid refrigerant in the vapor line during long periods of shutdown.

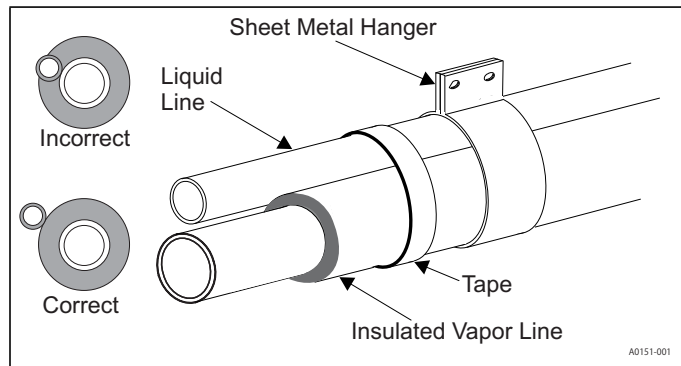

**FIGURE 2:** Installation of Vapor Line

7. Pack fiberglass insulation and a sealing material such as perma-gum around refrigerant lines where they penetrate a wall to reduce vibration and to retain some flexibility.
8. For systems with total line length exceeding 80 feet (24.38 m), see APPLICATION DATA and worksheet "General Piping Recommendations and Refrigerant Line Length" for vapor and liquid line sizing, calibration of liquid line pressure loss or gain, determination of vapor line velocity, elevation limitations, TXV connections, system charging, traps, etc.

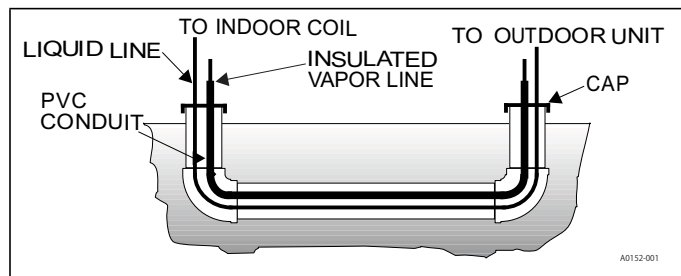

**FIGURE 3:** Underground Installation

## PRECAUTIONS DURING BRAZING OF LINES

All outdoor unit and evaporator coil connections are copper-to-copper and should be brazed with a phosphorous-copper alloy material such as Silfos-5, silver solder or equivalent. DO NOT use soft solder. The outdoor units have reusable service valves on both the liquid and vapor connections. The total system refrigerant charge is retained within the outdoor unit during shipping and installation. The reusable service valves are provided to evacuate and charge per this instruction.

Serious service problems can be avoided by taking adequate precautions to assure an internally clean and dry system.

### CAUTION

*Dry nitrogen should always be supplied through the tubing while it is being brazed, because the temperature required is high enough to cause oxidation of the copper unless an inert atmosphere is provided. The flow of dry nitrogen should continue until the joint has cooled. Always use a pressure regulator and safety valve to insure that only low pressure dry nitrogen is introduced into the tubing. Only a small flow is necessary to displace air and prevent oxidation.*

## PRECAUTIONS DURING BRAZING SERVICE VALVE

Precautions should be taken to prevent heat damage to service valve by wrapping a wet rag around it as shown in Figure 4. Also, protect all painted surfaces, insulation, and plastic base during brazing. After brazing, cool joint with wet rag.

### WARNING

*This is not a backseating valve. The service access port has a valve core. Opening or closing valve does not close service access port. If the valve stem is backed out past the chamfered retaining wall, the O-ring can be damaged causing leakage or system pressure could force the valve stem out of the valve body possibly causing personal injury.*

Valve can be opened by removing the service valve cap and fully inserting a hex wrench into the stem and backing out counter-clockwise until valve stem just touches the chamfered retaining wall.

#### Connect the refrigerant lines using the following procedure:

1. Remove the cap and Schrader core from both the liquid and vapor service valve service ports at the outdoor unit. Connect low pressure nitrogen to the liquid line service port.
2. Braze the liquid line to the liquid valve at the outdoor unit. Be sure to wrap the valve body with a wet rag. Allow the nitrogen to continue flowing.
3. Carefully remove the plugs from the evaporator liquid and vapor connections at the indoor coil.

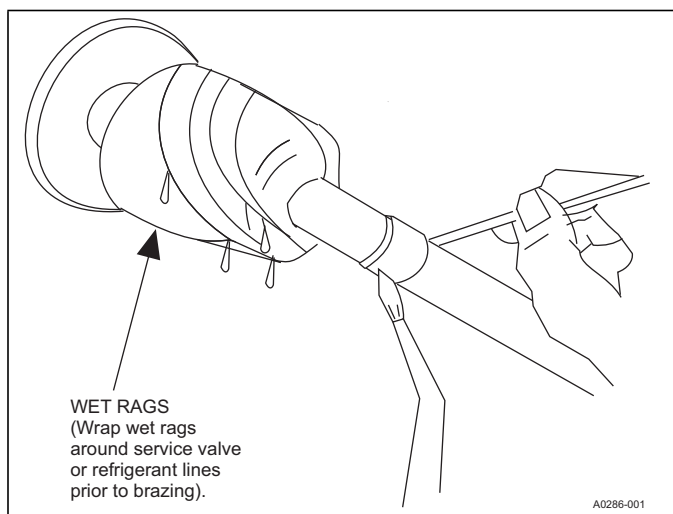

FIGURE 4: Heat Protection

### CAUTION

*Do not install any coil in a furnace which is to be operated during the heating season without attaching the refrigerant lines to the coil. The coil is under pressure which must be released to prevent excessive pressure build-up and possible coil damage.*

4. Braze the liquid line to the evaporator liquid connection. Nitrogen should be flowing through the evaporator coil.
5. Slide the grommet away from the vapor connection at the indoor coil. Braze the vapor line to the evaporator vapor connection. After the connection has cooled, slide the grommet back into original position.
6. Protect the vapor valve with a wet rag and braze the vapor line connection to the outdoor unit. The nitrogen flow should be exiting the system from the vapor service port connection. After this connection has cooled, remove the nitrogen source from the liquid fitting service port.
7. Replace the Schrader core in the liquid and vapor valves.
8. Go to SECTION IV for TXV installation.
9. Leak test all refrigerant piping connections including the service port flare caps to be sure they are leak tight. DO NOT OVERTIGHTEN (between 40 and 60 inch - lbs. maximum).

### NOTICE

*Line set and indoor coil can be pressurized to 250 psig with dry nitrogen and leak tested with a bubble type leak detector. Then release the nitrogen charge. Do not use the system refrigerant in the outdoor unit to purge or leak test.*

10. Evacuate the vapor line, evaporator, and liquid line to 500 microns or less.
11. Replace cap on service ports. Do not remove the flare caps from the service ports except when necessary for servicing the system.

### CAUTION

*Do not connect manifold gauges unless trouble is suspected. Approximately 3/4 ounce of refrigerant will be lost each time a standard manifold gauge is connected.*

12. Release the refrigerant charge into the system. Open both the liquid and vapor valves by removing the plunger cap and with an Allen wrench back out counter-clockwise until valve stem just touches the chamfered retaining wall. If the service valve is a ball valve, use a Crescent wrench to turn valve stem one-quarter turn counterclockwise to open. Do not overturn or the valve stem may break or become damaged. See "PRECAUTIONS DURING BRAZING SERVICE VALVE".
13. Replace plunger cap finger tight, then tighten an additional 1/2 turn (1/2 hex flat). Cap must be replaced to prevent leaks.

### WARNING

*Never attempt to repair any brazed connections while the system is under pressure. Personal injury could result.*

14. See "System Charge" section for checking and recording system charge.

## SECTION IV: INDOOR EXPANSION DEVICE

Before accomplishing the following procedures, verify the proper size TXV kit to be installed on the coil. Refer to supplied Tabular Data Sheet for specific TXV size and indoor coil match up.

### ⚠ CAUTION

Do not use slip joint pliers. Damage and distortion of distributor can prevent proper seal. Use appropriate sized adjustable end wrench.

### THERMOSTATIC EXPANSION VALVE (TXV) INSTALLATION

The following are basic steps for installation. For detailed instructions, refer to the Installation Instructions accompanying the TXV kit. Install TXV kit as follows:

### IMPORTANT

Refer to the Technical Guide for the unit to determine the proper TXV kit to be used on this product.

1. Relieve the indoor coil holding charge by depressing Schrader core on the suction manifold stub out.
2. After holding charge is completely discharged, loosen and remove the Schrader core.
3. Place a backup wrench on distributor, loosen and remove brass distributor nut. Retain brass nut for use on liquid line. Keep Teflon washer in place and discard clear disc.
4. Install the thermal expansion valve on the distributor assembly with supplied fittings. Ensure Teflon washer is seated in distributor. Hand tighten and turn an additional 1/4 turn to seal. Do not over-tighten fittings. See Figure 5.

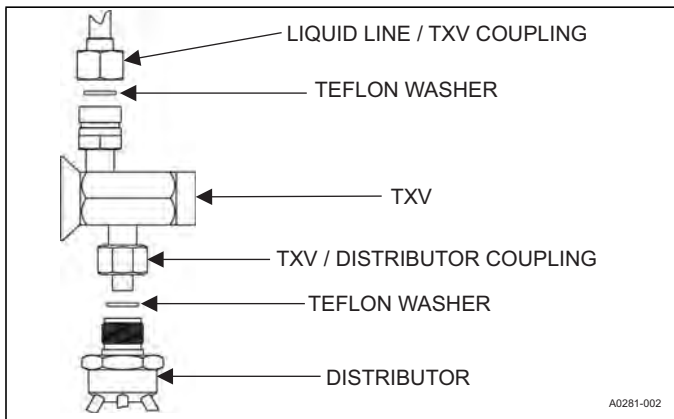

FIGURE 5: TXV Installation

### ⚠ CAUTION

Do not over torque. Do not use slip joint pliers. This will distort the aluminum distributor and the brass fitting (potentially causing leaks).

5. Slide the nut removed in step 3 over the supplied liquid line. Place supplied Teflon washer from TXV kit in place on TXV, and install liquid line to the top of the thermal expansion valve. Adjust assembly so liquid line aligns with hole in access panel. Hand tighten the liquid line, and apply an additional 1/4 turn to seal.

### ⚠ CAUTION

The vapor line Schrader valve core **MUST NOT** be installed with TXV equalizer line. If the valve core is left in place or installed, poor system performance or system failure could result.

6. Remove Schrader Core from the TXV equalizer port on the vapor line.
7. Install the TXV equalizer line onto the vapor line by hand tightening the 1/4" SAE coupling nut to the equalizer fitting, and apply an additional 1/3 turn to seal. See Figure 6.

### ⚠ CAUTION

In all cases, mount the TXV temperature sensing bulb after vapor line is brazed and sufficiently cooled.

8. Pass the TXV temperature sensing bulb through the suction line split grommet in the access panel.
9. Install the TXV bulb to the vapor line near the cabinet, using the bulb clamp(s) furnished with the TXV assembly. Ensure the bulb is making maximum contact. See Figures 6 and 7, and accomplish the following:
  - a. If possible, install the temperature bulb on a horizontal run of the vapor line. Ensure that the bulb is installed at a 10 o'clock or 2 o'clock position.
  - b. If bulb installation is made on a vertical run, ensure that the bulb is a minimum 8 inches (23.3 cm) away from elbow coming out of the coil. Position the bulb with the tail of the bulb at the top, so that the bulb acts as a reservoir. See Figure 8.
  - c. Bulb should be insulated using thermal insulation provided to protect it from the effect of the ambient temperature. Cover completely to insulate.
10. After line set is installed, leak test the system.

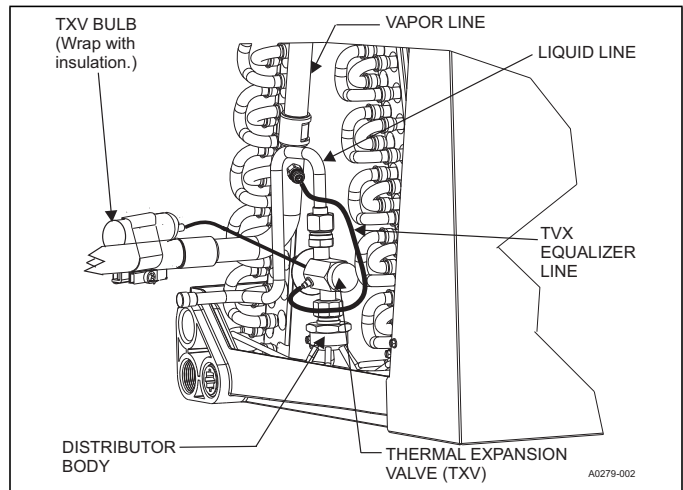

FIGURE 6: TXV Bulb Installation

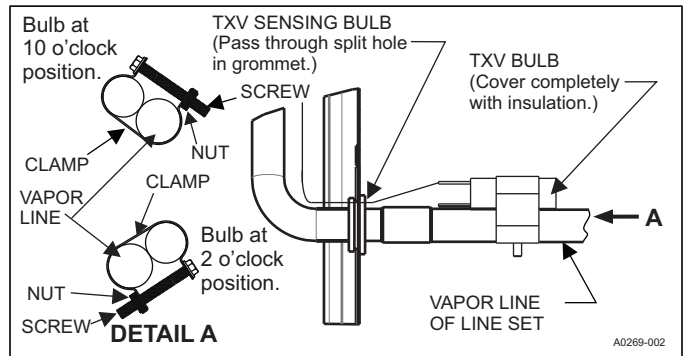

FIGURE 7: Proper Bulb Location

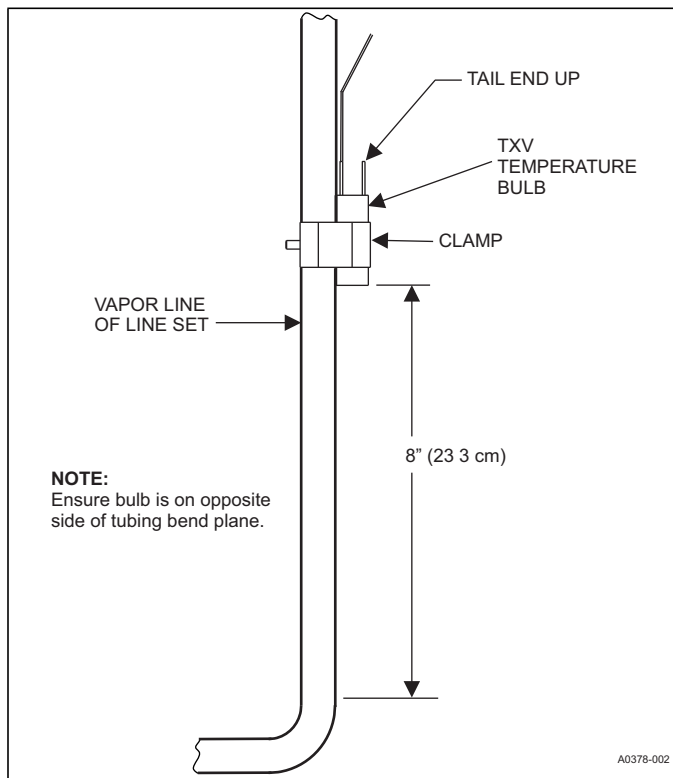

FIGURE 8: Vertical Temperature Bulb Orientation

## SECTION V: EVACUATION

If the coil has a stub out kit installed, evacuate the system to 500 microns or less. If a leak is suspected, leak test with dry nitrogen to locate the leak. Repair the leak and test again.

To verify that the system has no leaks, simply close the valve to the vacuum pump suction to isolate the pump and hold the system under vacuum. Watch the micron gauge for a few minutes. If the micron gauge indicates a steady and continuous rise, it's an indication of a leak. If the gauge shows a rise, then levels off after a few minutes and remains fairly constant, it's an indication that the system is leak free but still contains moisture and may require further evacuation if the reading is above 500 microns.

## SECTION VI: SYSTEM CHARGE

### ⚠ CAUTION

*Refrigerant charging should only be carried out by a licensed qualified air conditioning contractor.*

To ensure that your unit performs at the published levels, it is important that the indoor airflow is determined and refrigerant charge added accordingly.

### MEASURE INDOOR AIR FLOW

To determine rated air flow for a specific match, consult the technical literature at [www.upgnet.com](http://www.upgnet.com). When attempting to match this air flow, select the lowest possible speed tap, measure the actual flow, and adjust as necessary.

**To measure actual air flow, it is not an acceptable method to just check the jumper pin setting tables and to assume 0.5" static pressure drop.**

To determine indoor air flow, first measure the static pressure with a manometer between the filter and blower. On a single-piece air handler, take a second reading after the coil. On a furnace or modular air handler, take the second reading after the heat exchanger, but before the indoor coil. Add the negative return static to the positive supply static to determine the system total static pressure. Treat the negative return static as a positive pressure (even though it is a negative reading). If there is static pressure on the blower (i.e. -.10) return, add it to a supply static (.40) which equals a (.50) total system static pressure. Compare this value to the table for the indoor unit's static pressure vs. CFM or to a curve chart.

### CHARGING THE UNIT

### ⚠ CAUTION

*R-410A refrigerant cylinders are rose colored, and have a dip tube which allows liquid to flow out of the cylinder in the **Upright Position**. Always charge the system slowly with the tank in the upright position.*

The factory charge in the outdoor unit includes enough charge for the unit, 15 ft. (4.6 m) of refrigerant piping, and the smallest indoor coil/air handler match-up. Some indoor coil / air handler matches may require additional charge.

### ⚠ CAUTION

*Compressor damage will occur if system is improperly charged. On new system installations, charge system per tabular data sheet for the matched coil and follow guidelines in this instruction.*

See Tabular Data Sheet provided in unit Customer Booklet for charge requirements. The "TOTAL SYSTEM CHARGE" must be permanently marked on the unit data plate.

### ⚠ CAUTION

*Do not leave the system open to the atmosphere. Unit damage could occur due to moisture being absorbed by the POE oil in the system. This type of oil is highly susceptible to moisture absorption.*

### TOTAL SYSTEM CHARGE DETERMINED

1. Determine outdoor unit factory charge from Tabular Data Sheet.
2. Determine indoor coil adjustment (if any) from Tabular Data Sheet.
3. Calculate the additional charge for refrigerant piping using the Tabular Data Sheet if line length is greater than 15 feet (4.6 m).
4. Total system charge = item 1 + item 2 + item 3.
5. Permanently mark the unit data plate with the total amount of refrigerant in the system.

### NOTICE

*The P6 TEST MODE must be jumpered in the "H" position when charging the system. Before the system is charged, it takes approximately 15 minutes of cooling operation for the refrigerant in the system to stabilize. After charging is complete, the P6 TEST MODE must be jumpered in the "N" position for normal operation of the system. With the jumper in the "N" position, the compressor operates at 4th stage and Y2 operates the indoor fan speed.*

6. When charging system, move the P6 TEST MODE jumper from the normal "N" operating position to the high "H" position. After the system is completely charged, move the P6 TEST MODE jumper from the "H" position to the "N" position for normal operation. See Figure 9 for "H" and "N" jumper positions.
7. If a device is placed in the refrigerant lines, such as a drier, muffler, or liquid line flow meter, do not weigh in the charge. Instead, follow the directions in the "CHARGING WITH GAUGES" section.

**⚠ WARNING**

*DO NOT attempt to pump "Total System Charge" into outdoor unit for maintenance, service, etc. This may cause damage to the compressor and/or other components. Recover and weigh "System Charge" into an appropriate recovery cylinder for any instances requiring evacuation.*

**⚠ CAUTION**

*It is unlawful to knowingly vent, release or discharge refrigerant into the open air during repair, service, maintenance or the final disposal of this unit.*

CHARGING WITH GAUGES

**⚠ CAUTION**

*Refrigerant charging should only be carried out by a qualified air conditioning contractor.*

All units include a cooling charging chart for cooling. If a charging chart is not on the unit, then it can be obtained from [www.upgnet.com](http://www.upgnet.com).

**⚠ CAUTION**

*Compressor damage will occur if system is improperly charged. On new system installations, charge system per tabular data sheet for the matched coil and follow guidelines in this instruction.*

Before using gauges, confirm that your gauges are accurate by comparing the gauges against a calibrated pressure gauge that has been calibrated against a national standard. If a calibrated pressure gauge is not available, place a R-410A virgin refrigerant container in a conditioned space long enough to come to temperature equilibrium with the surroundings. Then measure the temperature of the air and the pressure of the refrigerant and compare it to the following table:

**TABLE 3: R-410A Saturation Properties**

Temp (°F)	Pressure (Psig)	Temp (°F)	Pressure (Psig)	Temp (°F)	Pressure (Psig)
40	119	75	218	110	365
45	130	80	236	115	391
50	143	85	255	120	418
55	156	90	274	125	447
60	170	95	295	130	477
65	185	100	317	—	—
70	201	105	341	—	—

Before measuring the pressures, use the method above to check the air flow and then consult the table and match the liquid pressure to that air flow with the proper amount of refrigerant.

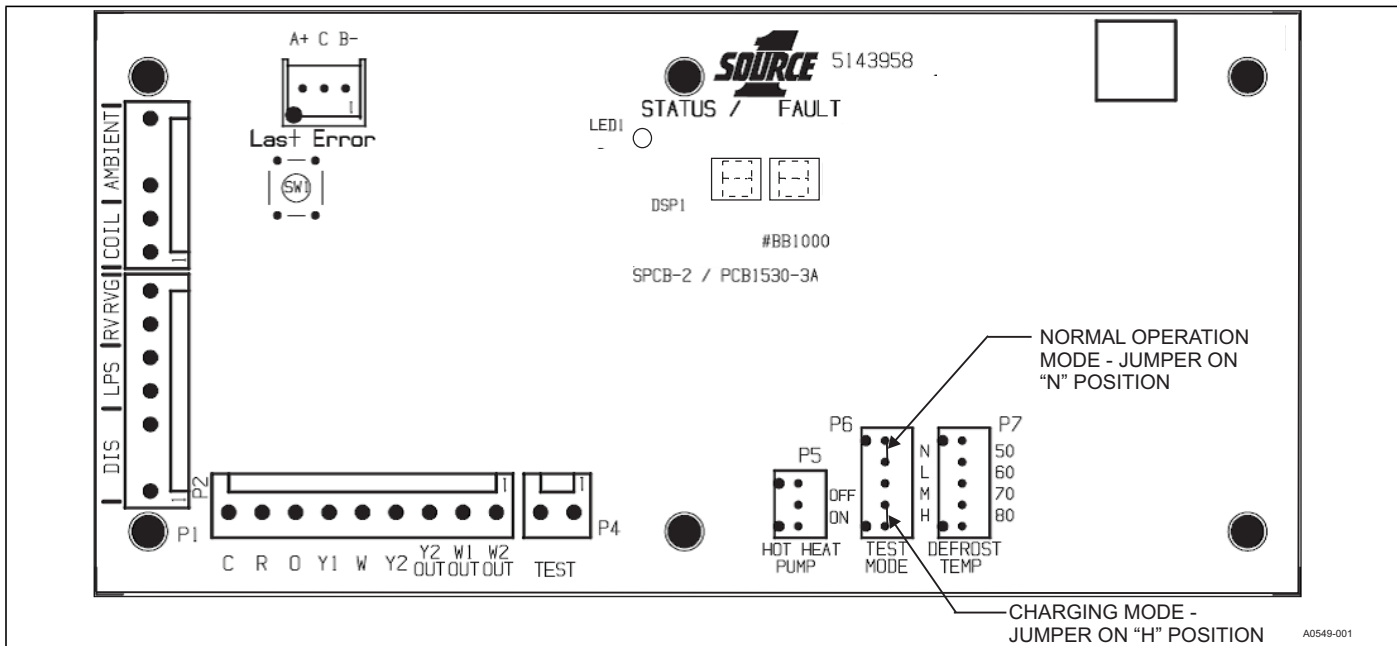

**FIGURE 9: Jumper Location for Charging Mode and Normal Operation Mode**



## SECTION VII: ELECTRICAL CONNECTIONS

### GENERAL INFORMATION & GROUNDING

The control box cover is held in place with 4 screws (one screw near each lower corner and one screw near each upper corner).

Check the electrical supply to be sure that it meets the values specified on the unit nameplate and wiring label.

Power wiring, control (low voltage) wiring, disconnect switches and over current protection must be supplied by the installer. Wire size should be sized per NEC requirements.

### CAUTION

All field wiring must **USE COPPER CONDUCTORS ONLY** and be in accordance with *Local, National, Fire, Safety & Electrical Codes*. This unit must be grounded with a separate ground wire in accordance with the above codes.

The complete connection diagram and schematic wiring label is located on the inside surface of the unit service access panel.

### FIELD CONNECTIONS POWER WIRING

1. Install the proper size weatherproof disconnect switch outdoors and within sight of the unit.
2. Remove the screws at the top and sides of the corner cover. Slide the control box cover down and remove from unit.
3. Run power wiring from the disconnect switch to the unit.
4. Route wires from disconnect through power wiring exit provided and into the unit control box as shown in Figures 1 and 10.
5. Install the proper size time-delay fuses or circuit breaker, and make the power supply connections.

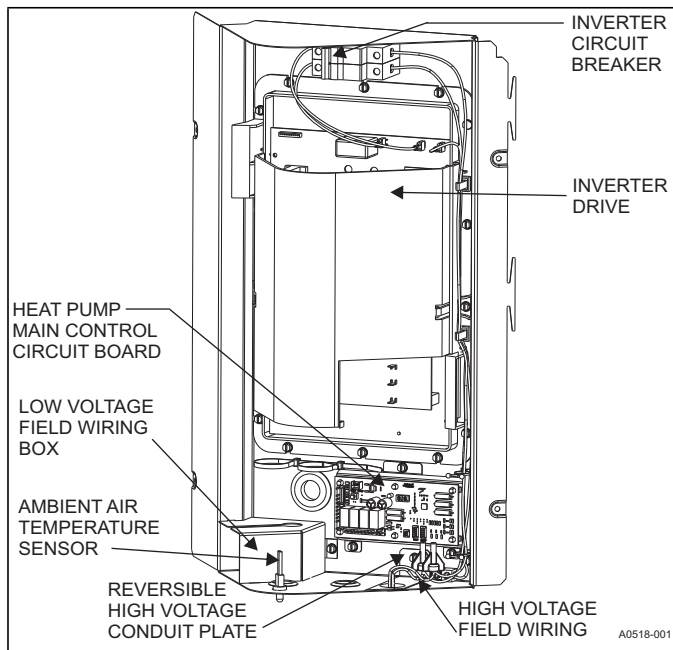

FIGURE 10: Outdoor Unit Control Box (Single Phase)

### FIELD CONNECTIONS CONTROL WIRING

1. Route low voltage wiring into bottom of control box as shown in Figure 10. Make low voltage wiring connections inside the low voltage box per Figure 11.
2. The complete connection diagram and schematic wiring label is located on the inside surface of the unit service access panel.
3. Replace the control box cover removed in Step 2 of the FIELD CONNECTIONS POWER WIRING procedures.
4. All field wiring to be in accordance with national electrical codes (NEC) and/or local-city codes.
5. Mount the thermostat about 5 ft. above the floor, where it will be exposed to normal room air circulation. Do not place it on an outside wall or where it is exposed to the radiant effect from exposed glass or appliances, drafts from outside doors or supply air grilles.
6. Route the 24-volt control wiring (NEC Class 2) from the outdoor unit to the indoor unit and thermostat.

### NOTICE

To eliminate erratic operation, seal the hole in the wall at the thermostat with permagum or equivalent to prevent air drafts affecting the operation of in the thermostat.

### DEHUMIDIFICATION CONTROL (Typical)

The indoor unit Installation Manual instructions for the air handler or furnace describe the interface with the outdoor heat pump. A dehumidification control accessory 2HU16700124 may be used with variable speed air handlers or furnaces in high humidity areas. This control works with the variable speed indoor unit to provide cooling at a reduced air flow, lowering evaporator temperature and increasing latent capacity. The humidistat in this control opens the humidistat contacts as the humidity rise. Installation instructions are packaged with the accessory. Prior to the installation of the dehumidification control, the humidistat jumper must be set to "YES" on the indoor variable speed air handler or furnace control board.

During cooling, if the relative humidity in the space is higher than the desired set point of the dehumidification control, the variable speed blower motor will operate at lower speed until the dehumidification control is satisfied. A 40-60% relative humidity level is recommended to achieve optimum comfort.

If a dehumidification control is installed, it is recommended that a minimum air flow of 325 cfm/ton be supplied at all times.

To see connection diagrams of all UPG equipment, the "Low Voltage System Wiring" document is available online at [www.upgnet.com](http://www.upgnet.com) in the Product Catalog Section.

### INDOOR CUBIC FEET PER MINUTE (CFM) SELECTION BOARD SETTINGS (Typical)

Refer to the indoor unit Installation Manual instructions for the air handler or furnace interface with the outdoor heat pump. Refer to the Outdoor Technical Guide for the recommended indoor air flow settings of each specific heat pump. For the system to operate correctly, ensure that the indoor CFM Selection control jumpers are properly set. Set the indoor cooling fan speed per the instructions for the air handler or furnace by selecting the correct COOL and ADJUST (or ADJ) taps. Verify the indoor airflow by using the LED display on the indoor CFM selection board.

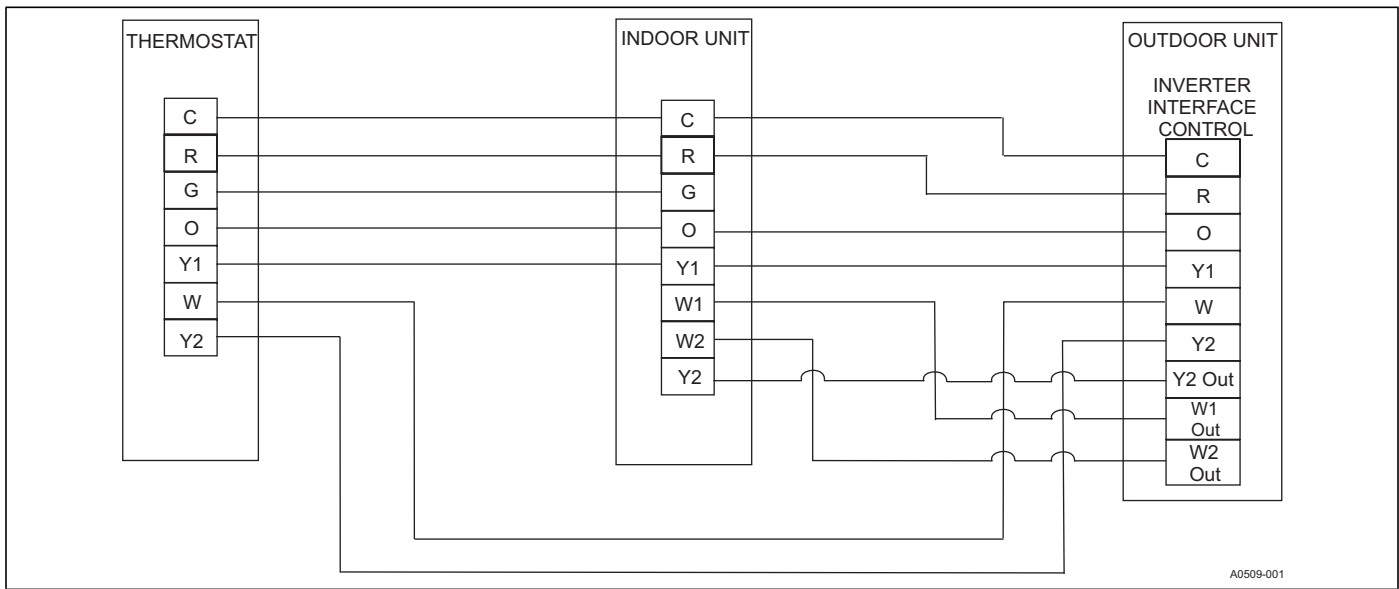

**FIGURE 11:** Typical Field Wiring (Air Handler / Electrical Heat) (Single-Phase)

**SECTION VIII: SYSTEM START-UP**  
ENERGIZE CRANKCASE HEATER

**▲ CAUTION**

*An attempt to start the compressor without at least 2 hours of crankcase heat will damage the compressor. When replacing the CCH, use the same 30 Watt CCH model which originally came with the unit.*

The control continually monitors the operation of the compressor. If the outdoor ambient temperature is below 55° F for 30 seconds continually while the compressor is off for 20 minutes, the control cycles the crankcase heater on for 10 minutes and off for 10 minutes until the outdoor ambient temperature is above 55° F for 30 seconds continually or the compressor speed reference is greater than zero.

**SECTION IX: SYSTEM OPERATION**  
ANTI SHORT-CYCLE DELAY

The control includes a five-minute anti short-cycle delay (ASCD) timer to prevent the compressor from short-cycling after a power or thermostat signal interruption. The ASCD timer is applied when the control is first powered from the indoor unit thermostat and immediately following the completion of a compressor run cycle. The compressor and the outdoor fan will not operate during the five minutes that the timer is active. The ASCD timer can be bypassed by shorting the TEST terminals for 2-5 seconds while the thermostat is calling for compressor operation (Y input signal energized).

**TABLE 4:** TEST Input Functionality with Y

Duration of connection (seconds)	Control behavior with thermostat signals present
Less than 2	No response
2 – 5	Bypass ASCD (Reduce timer to zero immediately). If “Y1” is present and the high-pressure switch is closed, the compressor is activated.
	Clear Pressure Switch Lockout, and reset the 6 hour PS timer.
Greater than 5	Initiate defrost cycle ignoring the COIL temp, and record that defrost cycle was initiated by TEST short. Defrost cycle is not initiated if “O” is present. Energize “W OUT,” and begin defrost cycle immediately upon expiration of timer.
Test Pin Short removed	Terminate defrost as normal.
Test pin Short not removed	Continue defrost cycle until TEST connection removed.

LOW VOLTAGE DETECTION

**IMPORTANT**

*When connecting low voltage system wiring, DO NOT connect terminal W to terminal W1 OUT and/or terminal W2 OUT. It can result in causing auxiliary or backup heat to lock on.*

The control monitors the transformer secondary (24 VAC) voltage and provides low voltage protection for the heat pump and its components. In particular, the control prevents contactor chatter during low voltage conditions. If the voltage drops below approximately 19 VAC, the control continues to energize any relays that are already energized, but the control can no longer energize any additional relays until the voltage level increases. If the voltage drops below approximately 16 VAC, the control immediately de-energizes the relay outputs and can no longer energize any relays until the voltage level increases. The control stores and displays the appropriate fault codes when low voltage conditions occur.

TEST INPUT

The control includes a TEST input connector that can be used for various testing functions during installation and service. The TEST input connector is shown in Figure 13. The following table summarizes the behavior of the control when the two TEST pins are connected. More detailed descriptions of the various functions are included in other sections of this document.

**TABLE 5: TEST Input Functionality without Y**

Duration of connection (seconds)	Control behavior with thermostat signals NOT present
Less than 2	No response
2 – 5	Display operational mode (AC or HP)
	Clear Pressure Switch Lockout and reset the 6 hour PS timer.
	Clear Fault
Greater than 5	Display operational mode (AC or HP)
Test Pin Short removed	Resume normal LED display
Test pin Short not removed	Display operational mode (AC or HP)

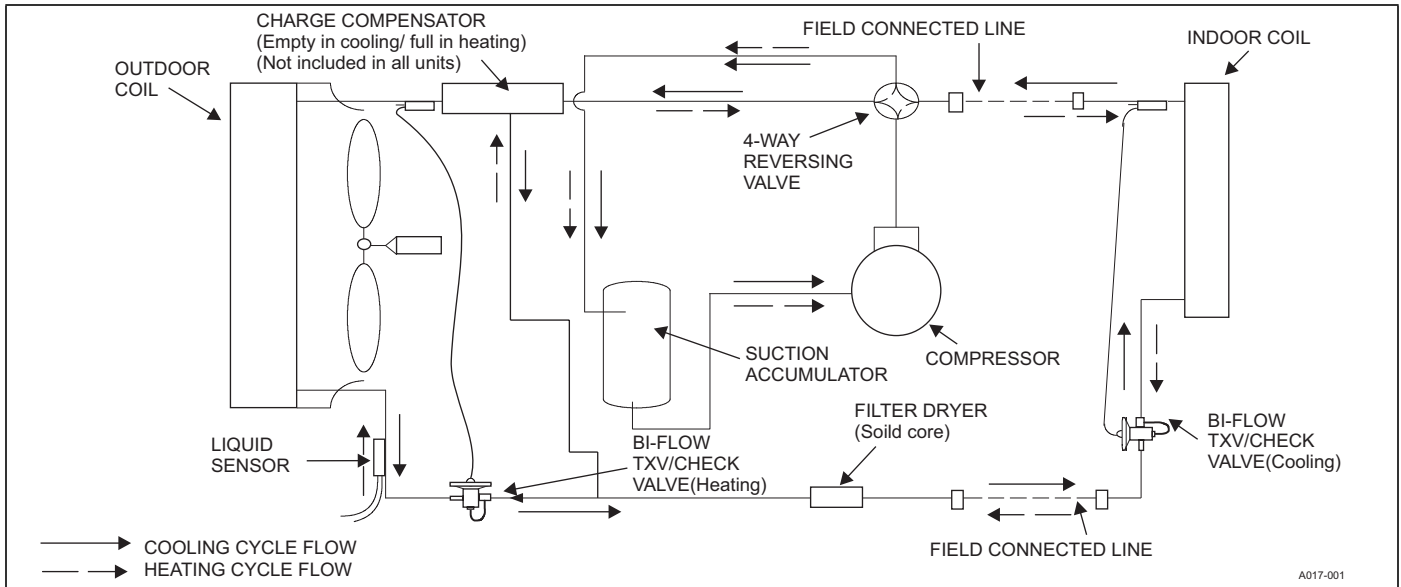

**FIGURE 12: Heat Pump Flow Diagram**

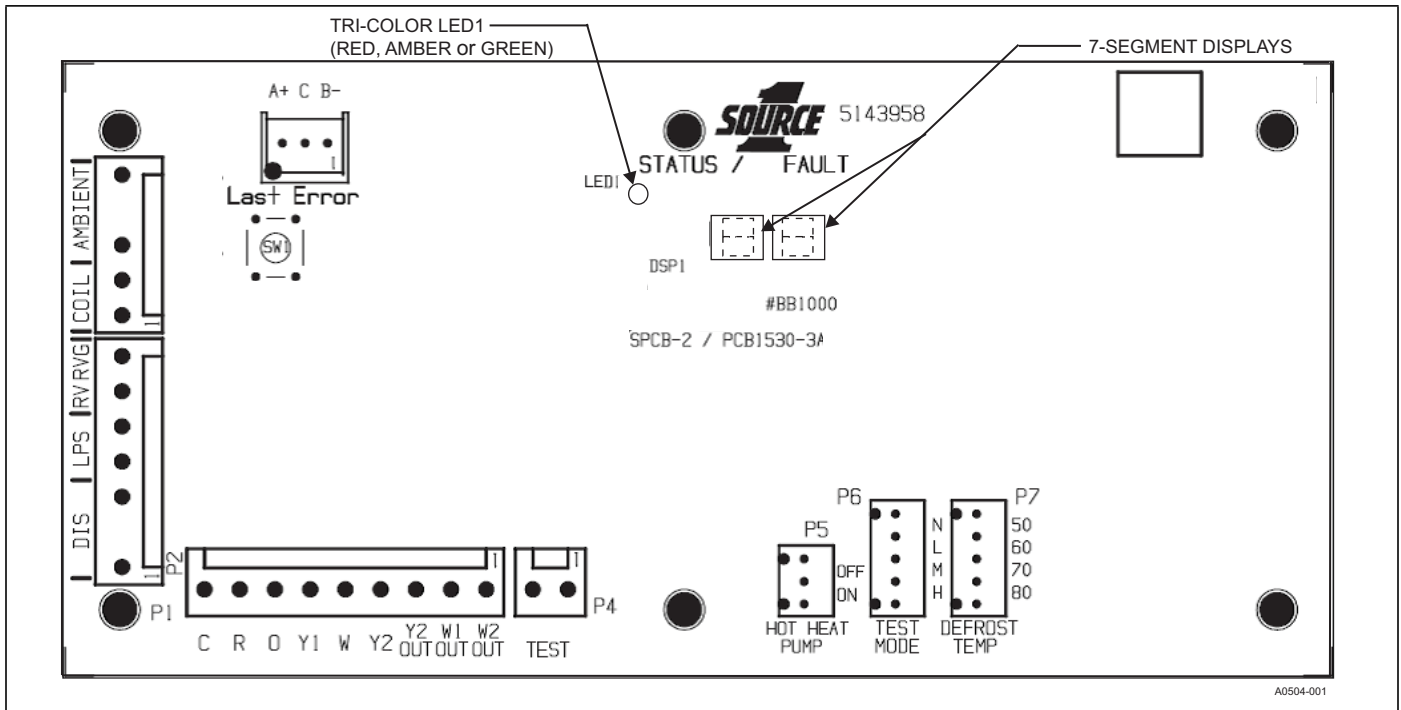

**FIGURE 13: Heat Pump Main Control Board**

## FAULT AND STATUS CODE BEHAVIOR

### Fault Code Storage

The control stores fault codes in non-volatile memory for review by the service technician for 30 days.

The control stores a maximum of the ten most recent fault codes. The control stores only one identical fault code during the same series of events. For example, if 2 or more high pressure switch (HPS) faults occur sequentially without another fault occurring in between the HPS faults, the control only stores the HPS fault once. These codes are stored even when power is removed from the control. The codes remain in the memory until the control is powered for 30 consecutive days or until the codes are cleared from the control. The fault codes are stored in order of occurrence and stamped from most recent display first in order to save them for the 30-day period.

**TABLE 6:** Status Code Display

Description	LED	Color	7-Segment Display 1	7-Segment Display 2
No power to control	OFF	OFF		
Control normal operation – no call for compressor (Standby Mode)	2s ON / 2s OFF ("Heartbeat")	Green		
Control normal operation – in ASCD period (COOLING)	0.1 sec ON / 0.1 sec OFF	Green		
Control normal operation – in ASCD period (HEATING)	0.1 sec ON / 0.1 sec OFF	Amber		
Any Fault code that would prevent the equipment from running	See Fault Codes	See Fault Codes		
No fault codes in memory	2 flashes	Green		
Fault code memory cleared	3 flashes	Green		
Stage 1 Heating	ON	Amber	H	1
Stage 2 Heating	ON	Amber	H	2
Stage 3 Heating	ON	Amber	H	3
Stage 4 Heating	ON	Amber	H	4
Stage 5 Heating	ON	Amber	H	5
Auxiliary Heat 1	ON	Amber	A	1
Auxiliary Heat 2	ON	Amber	A	2
Stage 1 Emergency Heat	ON	Amber	E	1
Stage 2 Emergency Heat	ON	Amber	E	2
Defrost	ON	Amber	O	F
Stage 1 Cooling	ON	Green	C	1
Stage 2 Cooling	ON	Green	C	2
Stage 3 Cooling	ON	Green	C	3
Stage 4 Cooling	ON	Green	C	4
Stage 5 Cooling	ON	Green	C	5

### Operational Mode Display

The control displays the units current operational mode through the 7-Segment Display (HP or AC) and the LED when the TEST input is shorted and the control is in standby mode. When the short is removed, the control returns to normal LED display. The operational modes are displayed according to Table 7. A multicolor LED is displayed to indicate the unit function in the operational mode.

## NOTICE

*In Table 7, the 7-Segment Displays 1 and 2 are indicators of how the control is configured. The control is to always display a heat pump configuration.*

*If the control displays AC, check connectors and cables to reversing valve coil for proper connection.*

**TABLE 7:** Operational Mode Display

Operational Mode	LED	Color	7-Segment Display 1	7-Segment Display 2
Heat Pump	1 flash	Green	H	P
Air Conditioner	2 flashes	Green	A	C

### Status Code Display

The control also provides status codes using the LED and the 7-segment displays. Status codes indicate the state of operation of the unit, but the status codes do not represent a fault. Table 6 describes the LED and the 7-segment displays during status codes. Status codes are not displayed when a fault code is present.

### Fault Code Display

The control provides fault codes using the Status LED and the 7-Segment displays. The table below describes the LED and the 7-Segment displays during fault codes. On the LED and the 7-Segment displays, the control displays a single fault code only. The control displays the fault code on the LED and the 7-Segment displays repeatedly with a 2 second off period between repetitions of the fault code. If multiple fault codes are present at the same time, the LED and the 7-Segment displays only the highest priority fault. The other active faults may be accessed via the LAST ERROR button on the control board.

Table 8 below shows the LED and the 7-Segment display representation for specified faults. For instance, a solid red LED with a 7-Segment display of 10 indicates an open OD ambient temperature sensor.

When any minor fault code (any fault that does not shut down compressor and OD Fan operation) is present, the control displays the corresponding minor fault code on the 7-Segment displays and alternates with the current stage of operation at a rate of 2 seconds.

Status codes are not displayed when a fault code is present.

TABLE 8: Fault Code Display

Description	LED	7-Segment Display 1	7-Segment Display 2
<b>Control Fault Code</b>			
Control Failure	RED (solid)	0	0
<b>Operational Fault Codes</b>			
High-pressure switch fault (not in lockout yet)	RED (solid)	0	1
System in high-pressure switch soft lockout (last mode of operation was normal compressor)	2 RED flashes	0	2
System in high-pressure switch hard lockout (last mode of operation was normal compressor)	3 RED flashes	0	2
System in high-pressure switch soft lockout (last mode of operation was defrost)	2 RED flashes	0	3
System in high-pressure switch hard lockout (last mode of operation was defrost)	3 RED flashes	0	3
Low-pressure switch soft lockout fault	2 RED flashes	0	4
Low-pressure switch hard lockout fault	3 RED flashes	0	4
Low Voltage (less than 19.2 VAC) preventing further relay outputs for greater than 2 seconds	RED (solid)	0	6
Low Voltage (less than 16 VAC) stopped current relay outputs for greater than 2 seconds	RED (solid)	0	7
Inverter Control Communications Fault	RED (solid)	0	8
<b>Sensor or Switch Fault Codes</b>			
Outdoor (OD) ambient temperature sensor failure (short)	RED (solid)	0	9
OD ambient temperature sensor failure (open)	RED (solid)	1	0
Coil (liquid line) sensor failure (short)	RED (solid)	1	1
Coil (liquid line) sensor failure (open)	RED (solid)	1	2
Discharge sensor failure (short)	RED (solid)	1	3
Discharge sensor failure (open)	RED (solid)	1	4
High discharge line temperature	RED (solid)	1	5
Low discharge line temperature	RED (solid)	1	6
<b>Wiring Related Fault Codes</b>			
"O" signal received in AC mode	RED (solid)	1	8
"W" signal received in AC mode	RED (solid)	1	9
"W" and "O" signal received in AC mode	RED (solid)	2	0
"W" and "O" signal received in HP mode	RED (solid)	2	4
<b>Mismatch Speed Fault Codes</b>			
Compressor Start Failure	Red (solid)	2	5
OD Fan Start Failure	Red (solid)	2	6
<b>Operating Envelope Threshold Errors</b>			
OD ambient temperature range of 109° F – 125° F (Cooling Mode)	RED (solid)	2	7
OD ambient temperature greater than 125° F (Cooling Mode)	RED (solid)	2	8
OD ambient temperature less than 35° F (Cooling Mode)	RED (solid)	2	9
<b>Inverter Drive - Major Fault Codes</b>			
Compressor inverter / protective fault control (PFC) fault	RED (solid)	3	1
Fan inverter fault	RED (solid)	3	2
Loss of Communication with inverter interface control	RED (solid)	3	3
DC over voltage (software protection)	RED (solid)	3	4
DC under voltage (software protection)	RED (solid)	3	5
Compressor inverter over current (software protection)	RED (solid)	3	6
Intelligence power module (IPM) over temperature	RED (solid)	3	7
DC over voltage – IPM	RED (solid)	3	8
DC under voltage – IPM	RED (solid)	3	9
Compressor speed misalignment	RED (solid)	4	0
Phase lost detected by speed	RED (solid)	4	1
Phase lost detected by current	RED (solid)	4	2
Compressor IPM fault – By rising and falling edges of insulated-gate bipolar transistor (IGBT) voltage	RED (solid)	4	3
Inverter pulse width modulation (PWM) logic error	RED (solid)	4	4
Inverter PWM initialization error	RED (solid)	4	5
Compressor inverter shunt resistor unbalanced	RED (solid)	4	6
Fan inverter IPM fault	RED (solid)	4	7
Fan inverter misalignment and locked rotor	RED (solid)	4	8
Fan inverter phase lost	RED (solid)	4	9

**TABLE 8:** Fault Code Display (Continued)

Description	LED	7-Segment Display 1	7-Segment Display 2
Fan inverter DC bus over and under voltage	RED (solid)	5	0
Fan inverter over current	RED (solid)	5	1
Compressor IPM fault – By low voltage of IGBT voltage	RED (solid)	5	2
Analog digital converter offset abnormal error	RED (solid)	5	3
Inverter drive soft lockout (3 major faults in 30 minutes)	2 RED flashes	5	4
Inverter drive hard lockout (4 inverter drive soft lockouts in 2 hours)	3 RED flashes	5	5
Crankcase heater fault	RED (solid)	5	6
<b>Inverter Drive - Minor Fault Codes</b>			
IPM over temperature (speed limiting)	RED (solid)	6	0
DC voltage low (speed limiting)	RED (solid)	6	1
Compressor inverter over current (speed limiting)	RED (solid)	6	2
DC voltage low (speed reducing)	RED (solid)	6	3
Compressor inverter over current (speed reducing)	RED (solid)	6	4
IPM over temperature (speed reducing)	RED (solid)	6	5

## SECTION X: FAULT CODE - INVERTER TROUBLESHOOTING

Inverter fault codes are displayed on the 7-segment displays shown in Figure 13. The first digit appears on the left 7-Segment Display 1 and the second digit appears on the right 7-Segment Display 2. To see a brief description of the fault code or how the LED signal is displayed, the two digit code from Tables 9 through 13 can be used to reference the two digit code shown in Table 8. The brief description of the fault code and the specific signal from the LED are recorded in the columns to the left of the 7-Segment Display codes in Table 8.

**TABLE 9:** High Pressure Switch (HPS) Fault

INVERTER FAULT CODE	FAULT DESCRIPTION	POSSIBLE CAUSES	ACTIONS
01, 02, 03	HPS	Verify the system has the correct amount of refrigerant.	Refer to the Product Technical Guide.
		Loose high pressure switch harness leads.	Check the high pressure switch harness.
		Pressure switch wire is disconnected from outdoor unit control board.	Check high pressure switch connection on the outdoor inverter control.
		"Cooling Mode" for outdoor airflow - too low or off.	Verify outdoor coil is clean. Verify outdoor fan motor is functioning. Verify there is airflow through the coil.
		"Heating Mode" for indoor airflow - too low or off.	Check Indoor coil for restriction. Check indoor blower for proper operation / rotation. Check duct work for excessive static pressure. If attached to zoning system, ensure smallest zone can handle minimum cubic feet per minute (CFM) requirements.
		Troubleshoot the pressure switch.	Bypass the pressure switch on the inverter wire harness, and Ohm out the high pressure switch.
	If fault remains.	Contact JCI Technical Services.	

**TABLE 10:** Compressor Inverter Drive Fault

INVERTER FAULT CODE	FAULT DESCRIPTION	POSSIBLE CAUSES	ACTIONS
38	Voltage DC over voltage - Intelligence Power Module (IPM)	<b>Step 1.</b> High supply line voltage (greater than 265 VAC).	Check supply voltage to the outdoor unit. (If high, contact utility provider.)
		<b>Step 2.</b> Verify fault clears.	If Fault is still persistent, go to Step 3.
		<b>Step 3.</b> Validate voltage (188 - 252 VAC).	Check supply voltage to the outdoor unit. (If high, contact utility provider.)
		<b>Step 4.</b> Inverter internal damage.	Change out the inverter drive. (Validate the fix. If the issue is persistent, reinstall the original inverter drive, and go to the last step.)
		<b>Last Step.</b> If fault remains.	Contact JCI Technical Services.
39	Voltage DC under voltage - IPM	<b>Step 1.</b> Low supply line voltage (less than 197 VAC).	Check supply voltage to the outdoor unit (If low, contact utility provider.)
		<b>Step: 2.</b> Loose wire in control box area. (Breaker terminal not secure.)	Loose wire: Check for loose wire in outdoor unit.
		<b>Step 3.</b> Verify fault clears.	If fault is still persistent, go to step 4.
		<b>Step 4.</b> Validate voltage (between 208 - 265 VAC).	Check supply voltage to the outdoor unit. (If low, contact utility provider.)
		<b>Step 5.</b> Inverter internal damage.	Change out the inverter drive (Validate the fix. If the issue is persistent, reinstall the original inverter drive, and go to the last step.)
		<b>Last Step.</b> If fault remains.	Contact JCI Technical Services.
40	Compressor Speed Misalignment	<b>Step 1.</b> Loose or incorrect wire connections.	Check incoming power leads and leads to the compressor plug. W: Red Wire (RED). V: Black Wire (BLK). U: Brown Wire (BRN).
		<b>Step 2.</b> Phase imbalance.	Check compressor winding resistance or miswire of compressor leads at the compressor terminals. 2 Ton 0.88 Ohm 3 Ton 0.53 Ohm 4 Ton 0.44 Ohm 5 Ton 0.29 Ohm W: Red Wire (RED). V: Black Wire (BLK). U: Brown Wire (BRN).
		<b>Step 3.</b> Inverter internal damage. (Possible damage to the compressor circuit of the inverter drive.)	Change out the inverter drive. (Validate the fix. If the issue is persistent, reinstall the original inverter drive, and go to step 4.)
		<b>Step 4.</b> Compressor internal damage.	Replace compressor. (Validate the fix. If the issue is persistent, reinstall the original compressor, and go to the last step.)
		<b>Last Step.</b> If fault remains.	Contact JCI Technical Services.

**TABLE 10:** Compressor Inverter Drive Fault (Continued)

INVERTER FAULT CODE	FAULT DESCRIPTION	POSSIBLE CAUSES	ACTIONS
41	Phase Lost - Detected by Speed	<b>Step 1.</b> Loose or incorrect wire connections.	Check incoming power leads, the leads to the compressor plug, and the OD fan terminals.
		<b>Step 2.</b> Phase imbalance.	Check compressor winding resistance or miswire of compressor leads at the compressor terminals and at the inverter drive. 2 Ton 0.88 Ohm 3 Ton 0.53 Ohm 4 Ton 0.44 Ohm 5 Ton 0.29 Ohm W: Red Wire (RED). V: Black Wire (BLK). U: Brown Wire (BRN).
		<b>Step 3.</b> Inverter internal damage.	Change out the inverter drive. (Validate the fix. If the issue is persistent, reinstall the original inverter drive, and go to step 4.)
		<b>Step 4.</b> Compressor internal damage.	Replace compressor. (Validate the fix. If the issue is persistent, reinstall the original compressor, and go to the last step.)
		<b>Last Step.</b> If fault remains.	Contact JCI Technical Services
42	Phase Lost - Detected by Current	<b>Step 1.</b> Loose or incorrect wire connections.	Check incoming power leads, the leads to the compressor plug, and the OD fan terminals. W: Red Wire (RED). V: Black Wire (BLK). U: Brown Wire (BRN).
		<b>Step 2.</b> Phase imbalance.	Check compressor winding resistance or miswire of compressor leads at the compressor terminals and at inverter drive. 2 Ton 0.88 Ohm 3 Ton 0.53 Ohm 4 Ton 0.44 Ohm 5 Ton 0.29 Ohm W: Red Wire (RED). V: Black Wire (BLK). U: Brown Wire (BRN).
		<b>Step 3.</b> Inverter internal damage.	Change out the inverter drive. (Validate the fix. If the issue is persistent, reinstall the original inverter drive, and go to step 4.)
		<b>Step 4.</b> Compressor internal damage.	Replace compressor. (Validate the fix. If the issue is persistent, reinstall the original compressor, and go to the last step)
		<b>Last Step.</b> If fault remains.	Contact JCI Technical Services.



TABLE 10: Compressor Inverter Drive Fault (Continued)

INVERTER FAULT CODE	FAULT DESCRIPTION	POSSIBLE CAUSES	ACTIONS
43	Compressor IPM Fault – By Rising and Falling Edges of Insulated-Gate Bipolar Transistor (IGBT) Voltage	<b>Step 1.</b> Verify the system has the correct amount of refrigerant.	Refer to the Product Technical Guide.
		<b>Step 2.</b> Sudden supply voltage change.	Check supply voltage to the outdoor unit. (If low or high, contact utility provider.) (Inverter is not designed for use with a generator.) (Brownout condition.) (Check for a cut or damaged wire short to ground.)
		<b>Step 3.</b> Sudden load change on the fan motor.	Troubleshoot outdoor fan motor & blade. (Ensure they are in good working order.) Check fan harness and connectors.
		<b>Step 4.</b> Inverter internal damage.	Change out the inverter drive. (Validate the fix. If the issue is persistent, reinstall the original inverter drive, and go to step 5.)
		<b>Step 5.</b> Compressor internal damage.	Replace Compressor. (Validate the fix. If the issue is persistent, reinstall the original compressor, and go to the last step.)
		<b>Last Step.</b> If fault remains.	Contact JCI Technical Services.
52	Compressor IPM Fault – By Low Voltage of IGBT Voltage	<b>Step 1.</b> Verify the system has the correct amount of refrigerant.	Refer to the Product Technical Guide.
		<b>Step 2.</b> Sudden supply voltage change.	Check supply voltage to the outdoor unit. (If low or high, contact utility provider.) (Inverter is not designed for use with a generator.) (Brownout condition.) (Check for a cut or damaged wire short to ground.)
		<b>Step 3.</b> Sudden load change on the fan motor.	Troubleshoot outdoor fan motor & blade. (Ensure they are in good working order.) Check fan harness and connectors.
		<b>Step 4.</b> Inverter internal damage.	Change out the inverter drive. (Validate the fix. If the issue is persistent, reinstall the original inverter drive, and go to step 5.)
		<b>Step 5.</b> Compressor internal damage.	Replace compressor (Validate the fix. If the issue is persistent, reinstall the original compressor, and go to the last step.)
		<b>Last Step.</b> If fault remains.	Contact JCI Technical Services.
44	Inverter Pulse Width Modulation (PWM) Logic Error	<b>Step 1.</b> Loose or incorrect wire connections.	Check compressor winding resistance or miswire of compressor leads at the compressor terminals and at inverter drive. 2 Ton 0.88 Ohm 3 Ton 0.53 Ohm 4 Ton 0.44 Ohm 5 Ton 0.29 Ohm W: Red Wire (RED). V: Black Wire (BLK). U: Brown Wire (BRN).
		<b>Step 2.</b> Inverter internal damage.	Change out the inverter drive. (Validate the fix. If the issue is persistent, reinstall the original inverter drive, and go to step 3.)
		<b>Step 3.</b> Compressor internal damage.	Replace Compressor. (Validate the fix. If the issue is persistent, reinstall the original compressor, and go to the last step.)
		<b>Last Step.</b> If fault remains.	Contact JCI Technical Services.

**TABLE 10:** Compressor Inverter Drive Fault (Continued)

INVERTER FAULT CODE	FAULT DESCRIPTION	POSSIBLE CAUSES	ACTIONS
45	Inverter PWM Initialization Error	<b>Step 1.</b> Loose or incorrect wire connections.	Check incoming power leads and leads to the compressor plug. W: Red Wire (RED). V: Black Wire (BLK). U: Brown Wire (BRN).
		<b>Step 2.</b> Phase imbalance.	Check compressor winding resistance or miswire of compressor leads at the compressor terminals and at inverter drive. 2 Ton 0.88 Ohm 3 Ton 0.53 Ohm 4 Ton 0.44 Ohm 5 Ton 0.29 Ohm W: Red Wire (RED). V: Black Wire (BLK). U: Brown Wire (BRN).
		<b>Step 3.</b> Inverter internal damage.	Change out the inverter drive. (Validate the fix, If the issue is persistent, reinstall the original inverter drive, and go to step 4.)
		<b>Step 4.</b> Compressor internal damage.	Replace compressor. (Validate the fix, If the issue is persistent, reinstall the original compressor and go to the last step.)
		<b>Last Step.</b> If fault remains.	Contact JCI Technical Services.
46	Compressor Inverter Shunt Resistor Unbalanced	<b>Step 1.</b> Loose or incorrect wire connections.	Check incoming power leads and leads to the compressor plug. W: Red Wire (RED). V: Brown Wire (BRN). U: Black Wire (BLK).
		<b>Step 2.</b> Phase imbalance.	Check compressor winding resistance or miswire of compressor leads at the compressor terminals and at inverter drive. 2 Ton 0.88 Ohm 3 Ton 0.53 Ohm 4 Ton 0.44 Ohm 5 Ton 0.29 Ohm W: Red Wire (RED). V: Black Wire (BLK). U: Brown Wire (BRN).
		<b>Step 3.</b> Inverter internal damage.	Change out the inverter drive. (Validate the fix. If the issue is persistent, reinstall the original inverter drive, and go to step 4.)
		<b>Step 4.</b> Compressor internal damage.	Replace compressor. (Validate the fix. If the issue is persistent, reinstall the original compressor, and go to the last step.)
		<b>Last Step.</b> If fault remains.	Contact JCI Technical Services.

**TABLE 10:** Compressor Inverter Drive Fault (Continued)

INVERTER FAULT CODE	FAULT DESCRIPTION	POSSIBLE CAUSES	ACTIONS
53	Analog to Digital Conversion Error	<b>Step 1.</b> Loose or incorrect wire connections.	Check incoming power leads and leads to the compressor plug. W: Red Wire (RED). V: Black Wire (BLK). U: Brown Wire (BRN).
		<b>Step 2.</b> Phase imbalance.	Check compressor winding resistance or miswire of compressor leads at the compressor terminals and at inverter drive. 2 Ton 0.88 Ohm 3 Ton 0.53 Ohm 4 Ton 0.44 Ohm 5 Ton 0.29 Ohm W: Red Wire (RED). V: Black Wire (BLK). U: Brown Wire (BRN).
		<b>Step 3.</b> Inverter internal damage.	Change out the inverter drive. (Validate the fix. If the issue is persistent, reinstall the original inverter drive, and go to step 4.)
		<b>Step 4.</b> Compressor internal damage.	Replace compressor. (Validate the fix. If the issue is persistent, reinstall the original compressor, and go to the last step.)
		<b>Last Step.</b> If fault remains.	Contact JCI Technical Services.

**TABLE 11:** Outdoor Fan Motor Fault

INVERTER FAULT CODE	FAULT DESCRIPTION	POSSIBLE CAUSES	ACTIONS
48	Fan Inverter Misalignment and Locked Rotor	<b>Step 1.</b> Loose or incorrect fan motor wiring.	Check outdoor fan motor connectors and harness.
		<b>Step 2.</b> Outdoor fan blade restricted.	Check outdoor fan blade. Check for ice build up.
		<b>Step 3.</b> Outdoor fan blade bent or out of balance.	Check outdoor fan blade. Check for ice build up.
		<b>Step 4.</b> Bad outdoor fan motor.	Replace outdoor fan motor. (Validate the fix. If the issue is persistent, reinstall the original fan motor, and go to step 5.)
		<b>Step 5.</b> Inverter internal damage.	Change out the inverter drive. (Validate the fix. If the issue is persistent, reinstall the original inverter drive, and go to the last step.)
		<b>Last Step.</b> If fault remains.	Contact JCI Technical Services.

**TABLE 11:** Outdoor Fan Motor Fault (Continued)

INVERTER FAULT CODE	FAULT DESCRIPTION	POSSIBLE CAUSES	ACTIONS
49	Fan Inverter Phase Lost	<b>Step 1.</b> Loose or incorrect fan motor wiring.	Check incoming power leads and leads to the OD fan motor plug.
		<b>Step 2.</b> Phase imbalance.	Check outdoor fan winding resistance or miswire of the OD fan plug at the OD fan terminals. R: White Wire (White). S: Blue Wire (Blue). T: Orange Wire (Orange).
		<b>Step 3.</b> Inverter internal damage.	Change out the inverter drive. (Validate the fix. If the issue is persistent, reinstall the original inverter drive, and go to step 4.)
		<b>Step 4.</b> Fan motor internal damage.	Replace outdoor fan motor. (Validate the fix. If the issue is persistent, reinstall the original fan motor, and go to the last step.)
		<b>Last Step.</b> If fault remains.	Contact JCI Technical Services.
50	Fan Inverter DC Bus Over and Under Voltage	Step 1. Low supply line voltage (less than 187 VAC).	Check supply voltage to the outdoor unit. (If low, contact utility provider.)
		<b>Step 2.</b> Loose wire in control box area. (Breaker terminal not secure.)	Loose wire: Check for loose wire in outdoor unit.
		<b>Step 3.</b> High supply line voltage (greater than 253 VAC).	Check supply voltage to the outdoor unit. (If high, contact utility provider.)
		<b>Step 4.</b> Inverter internal damage.	Change out the inverter drive. (Validate the fix. If the issue is persistent, reinstall the original inverter drive, and go to step 5.)
		<b>Step 5.</b> Bad outdoor fan motor.	Replace outdoor fan motor. (Validate the fix. If the issue is persistent, reinstall the original fan motor, and go to the last step.)
		<b>Last Step.</b> If fault remains.	Contact JCI Technical Services.
51	Fan Inverter Over Current	<b>Step 1.</b> Sudden supply voltage change.	Check supply voltage to the outdoor unit. (If low or high, contact utility provider.) (Inverter is not designed for use with a generator.) (Possible brownout condition.) (Check for a cut or damaged wire short to ground.)
		<b>Step 2.</b> Sudden load change on the fan motor.	Troubleshoot outdoor fan motor & blade. (Ensure they are in good working order.) Check fan harness and connectors.
		<b>Step 3.</b> Inverter internal damage.	Change out the inverter drive. (Validate the fix. If the issue is persistent, reinstall the original inverter drive, and go to the last step.)
		<b>Last Step.</b> If fault remains.	Contact JCI Technical Services.

TABLE 11: Outdoor Fan Motor Fault (Continued)

INVERTER FAULT CODE	FAULT DESCRIPTION	POSSIBLE CAUSES	ACTIONS
47	Fan Inverter IPM Fault	<b>Step 1.</b> Sudden supply voltage change.	Check supply voltage to the outdoor unit. (If low or high, contact utility provider.) (Inverter is not designed for use with a generator.) (Brownout condition.) (Check for a cut or damaged wire short to ground.)
		<b>Step 2.</b> Sudden load change on the fan motor.	Troubleshoot outdoor fan motor & blade. (Ensure they are in good working order.) Check fan harness and connectors.
		<b>Step 3.</b> Inverter internal damage.	Change out the inverter drive. (Validate the fix. If the issue is persistent, reinstall the original inverter drive, and go to step 4.)
		<b>Step 4.</b> Fan motor internal damage.	Replace outdoor fan motor. (Validate the fix. If the issue is persistent, reinstall the original fan motor, and go to the last step.)
		<b>Last Step.</b> If fault remains.	Contact JCI Technical Services.

TABLE 12: Compressor Control Protection Fault

INVERTER FAULT CODE	FAULT DESCRIPTION	POSSIBLE CAUSES	ACTIONS
33	Loss of Communication with Inverter Interface Control	<b>Step 1.</b> Broken or damaged communication harness. (communication hardness.)	Replace communication harness. (Validate the fix, and go to Step 2.)
		<b>Step 2.</b> Loose or disconnected communication harness. (Communication hardness.)	Validate harness connection.
		<b>Step 3.</b> Radio or electrical noise.	System tries to self-mitigate with repeated start attempts until communications is regained.
		<b>Step 4.</b> Faulty inverter interface control.	Change out the inverter interface control. Validate the fix. if the issue is persistent, reinstall the original inverter interface control, and go to step 5.
		<b>Step 5.</b> Faulty inverter drive control.	Change out the inverter drive. Validate the fix, If the issue is persistent, reinstall the original inverter drive, and go to the last step.)
		<b>Last Step.</b> If fault remains.	Contact JCI Technical Services.
34	DC over Voltage Software Protection	<b>Step 1.</b> High supply line voltage (greater than 253 VAC).	Check supply voltage to the outdoor unit. (If high, contact utility provider.)
		<b>Step 2.</b> Verify fault clears.	If fault is still persistent; go to step 3.
		<b>Step 3.</b> Validate voltage (230 VAC).	Check supply voltage to the outdoor unit. (If high, contact utility provider.)
		<b>Step 4.</b> Inverter internal damage.	Change out the inverter drive. (Validate the fix. If the issue is persistent, reinstall the original inverter drive, and go to the last step.)
		<b>Last Step.</b> If fault remains.	Contact JCI Technical Services.

TABLE 12: Compressor Control Protection Fault (Continued)

INVERTER FAULT CODE	FAULT DESCRIPTION	POSSIBLE CAUSES	ACTIONS
35	DC under Voltage Software Protection	<b>Step 1.</b> Low supply line voltage (less than 187 VAC).	Check supply voltage to the outdoor unit. (If low, contact utility provider.)
		<b>Step 2.</b> Loose wire in control box area. (Breaker terminal not secure.)	Loose wire: Check for loose wire in outdoor unit. Verify bench circuit is sized right.
		<b>Step 3.</b> Verify fault clears.	If fault is still persistent, go to step 4.
		<b>Step 4.</b> Validate voltage (230 VAC).	Check supply voltage to the Outdoor Unit. (If low, contact utility provider.)
		<b>Step 5.</b> Inverter internal damage.	Change out the inverter drive. (Validate the fix. If the issue is persistent, reinstall the original inverter drive, and go to the last step.)
		<b>Last Step.</b> If fault remains.	Contact JCI Technical Services.
36	Compressor Inverter Over Current	<b>Step 1.</b> Verify the system has the correct amount of refrigerant.	Refer to the Product Technical Guide.
		<b>Step 2.</b> Compressor is operating outside the allowed operational envelope.	Inverter reduces speed to a lower compressor speed. (High ambient conditions.) (If compressor speed is reduced in moderate ambient conditions, check the deflector shield for a blockage or debris against the inverter heat sink.)
		<b>Step 3.</b> Incoming power supply voltage.	Check voltage versus unit rating plate for allowable range.
		<b>Step 4.</b> Loose or incorrect wire connections.	Check incoming power leads and leads to the com- pressor plug and at inverter drive. W: Red Wire (RED). V: Black Wire (BLK). U: Brown Wire (BRN).
		<b>Step 5.</b> Phase imbalance.	Check compressor winding resistance or miswire of compressor leads at the compressor terminals. W: Red Wire (RED). V: Black Wire (BLK). U: Brown Wire (BRN).
		<b>Step 6.</b> Outdoor airflow is too low or off in "Cooling Mode."	Check outdoor coil for clogging (ice or debris), and clean or de-ice if necessary. Troubleshoot outdoor fan motor, and make sure it is working. Follow "Outdoor Fan Motor Fault" troubleshooting instruction.
		<b>Step 7.</b> Inverter internal damage.	Change out the inverter drive. (Validate the fix. If the issue is persistent, reinstall the original inverter drive, and go to step 8.)
		<b>Step 8.</b> Compressor internal damage.	Replace compressor. (Validate the fix. If the issue is persistent, reinstall the original compressor, and go to the last step.)
		<b>Last Step.</b> If fault remains.	Contact JCI Technical Services.

**TABLE 12:** Compressor Control Protection Fault (Continued)

INVERTER FAULT CODE	FAULT DESCRIPTION	POSSIBLE CAUSES	ACTIONS
37	Intelligence Power Module (IPM) Over Temperature	<b>Step 1.</b> Outdoor airflow is too low or off in “Cooling Mode.”	Check outdoor coil for clogging (ice or debris), and clean or de-ice if necessary. Troubleshoot outdoor fan motor and make sure it is working. Follow “Outdoor Fan Motor Fault” troubleshooting instruction.
		<b>Step 2.</b> Inverter internal damage. (Field cannot troubleshoot to the component level between the circuit board and the heat sink.)	Change out the inverter drive. (Validate the fix. If the issue is persistent, reinstall the original inverter drive, and go to step 3.)
		<b>Step 3.</b> Fan motor internal damage.	Replace outdoor fan motor. (Validate the fix. If the issue is persistent, reinstall the original OD fan motor, and go to the last step.)
		<b>Last Step.</b> If fault remains.	Contact JCI Technical Services.

**TABLE 13:** Miscellaneous Fault Codes

INVERTER FAULT CODE	FAULT DESCRIPTION	POSSIBLE CAUSES	ACTIONS
56	Crankcase Heater (CCH) Fault	<b>Step 1.</b> Short crankcase heater circuit.	Troubleshoot the crankcase heater (CCH) with a multi-meter. Remove CCH terminals, and measure resistance across the CCH terminals. If CCH resistance value is outside 1824 - 2015 Ohms @ 77°F (25°C), replace the CCH.
		<b>Step 2.</b> Open crankcase heater circuit.	Troubleshoot the CCH with a multi-meter. Remove CCH terminals, and measure resistance across the CCH terminals. If the CCH resistance value reads infinity or open load, replace the CCH.
31	Compressor Inverter / Protective Fault Current (PFC)	<b>Step 1.</b> If any compressor malfunctions occur, this fault displays.	Troubleshoot the compressor. This fault occurs ONLY when there are issues with the compressor.
		<b>Last Step.</b> If fault remains.	Contact JCI Technical Services.
32	Fan Inverter Fault	<b>Step 1.</b> If any OD fan malfunctions occur, this fault displays.	Troubleshoot the fan. This fault occurs ONLY when there are issues with the outdoor fan.
		<b>Last Step.</b> If fault remains.	Contact JCI Technical Services.

## DEFROST OPERATION

The control uses an adaptive defrost operation. The control stores four unique settings which allows the control to defrost differently depending on the selected setting. This is done by changing the terminate temperature at which the defrost is terminated. This selection is made through a selectable shunt jumper on the control marked “**DEFROST TEMP.**”

Should 6 hours of “Compressor Run Time” (accumulated runtime during a heating call) elapse without a defrost cycle, a defrost cycle is initiated immediately. If the OD ambient temperature is less than 50° F at the 6 hour defrost, then the system is forced into a 6 minute defrost to allow oil return to the compressor. This occurs regardless of the coil temperature. If the OD ambient temperature is greater than 50° F at the 6 hour defrost, then the system terminates the defrost normally.

### Defrost Enable Temperature

The defrost enable temperature is 35° F. If the coil temperature is above 35°F and the compressor is active, the system does not accumulate defrost run time. It does however accumulate “Compressor Run Time” for purposes of running the 6 hour defrost. If the coil temperature is below 35° F and the compressor is active, the system accumulates “Defrost Run Time” and accumulates “Compressor Run Time” (for purposes of running the 6 hour defrost).

### Defrost Calibration Mode

The system is considered uncalibrated when power is applied after cool mode operation. All defrost calibration modes are cleared when power is applied to the control board. Calibration of the control occurs after a defrost cycle to ensure that there is no ice on the OD coil. During calibration, the temperature of both the coil and ambient temperature sensors are measured to establish a Frost Free Delta T (FFD T), which is (Amb T – Coil T).

When the control is in an uncalibrated state, the control initiates a sacrificial defrost after 31 minutes of accumulated compressor runtime in heating mode with coil temperature below 35° F. The defrost cycle terminates if the coil sensor reaches the selected termination temperature or after a 12 minute defrost.

Once the sacrificial defrost is terminated, a non-iced clear coil condition or FFD T is established by averaging coil temperature readings once a minute (for 4 minutes) starting on the 5th minute following termination of the last defrost. At that point, the “FFD T” and the Outdoor Ambient Temperature are stored as the “Calibrated Ambient Temperature” (c Amb T). From this a linear curve the “Frost Free Curve” (FFC) is developed. This FFC is the curve the system utilizes for the next defrost cycle. The current ambient temperature is still a variable and changes the FFC value as the ambient temperature changes until the next defrost occurs.

As the ambient temperature changes, a slope of 1° F Defrost Delta T Changes for every 8° F ambient temperature change which is used to adjust the detection of frost accumulation.

If a heating call ends during the process of re-evaluating the clear coil temperature, it utilizes the previously stored averaged values from the previous cycle. In other words, the utilized value must not be cleared until the 4 values are averaged and that value is ready to populate the utilized value. If no previously stored averaged values exist, the control remains uncalibrated and attempts calibration at the next defrost, depending on the terminating condition.

After initial calibration has been completed, the control prevents a defrost occurrence for 31 minutes of accumulated runtime in order to avoid unnecessary defrost operation due to system transient conditions.

#### Defrost Initiation

To activate a defrost sequence, the “O” thermostat input must NOT be active and the coil temperature must be below 35° F. When these conditions are met, the “Defrost Run Time” timer tracks the compressor output, and accumulates “Defrost Run Time” in the heating mode.

If the coil temperature is above 35° F, the “Defrost Run Time” timer is not cleared, and it does not accumulate run time. If the coil temperature is above the selected “Defrost Temp” (termination temperature), the “Defrost Run Time” timer is cleared. If the “O” thermostat input is active, the “Defrost Run Time” timer is cleared.

When the “Defrost Run Time” timer reaches 31 minutes, the defrost mode is enabled and executes as described depending on what mode of operation the control is in; either “Time/Temperature Defrost Mode” or “Demand Defrost Mode.”

#### Time/Temperature Defrost Mode

The control enters “Time/Temperature Defrost Mode” if the last defrost terminates due to “Defrost Cycle Time” and the Coil T is less than 35° F for greater than 4 minutes. When the “Defrost Run Time” timer reaches 31 minutes, the defrost operation initiates immediately. Depending on how the control exits the new defrost cycle, the system determines which defrost mode the control remains in or enters. This can be seen in Figure 14.

#### Demand Defrost Mode

The control enters “Demand Defrost Mode” if the last defrost terminates due to “Defrost Temp” (Termination Temperature) or the last defrost terminates due to “Defrost Cycle Time” and the Coil T is above 35° F for more than 4 minutes. Then when the “Defrost Run Time” timer reaches 31 minutes, the defrost operation initiates as a result of Frost Detection.

#### Frost Detection:

The control detects frost accumulation on the outdoor coil and initiates a defrost cycle when the current delta T (Amb T minus Coil T) is less than or equal to “Defrost Active Variable” (DAV) for the current outdoor ambient temperature for 5 seconds.

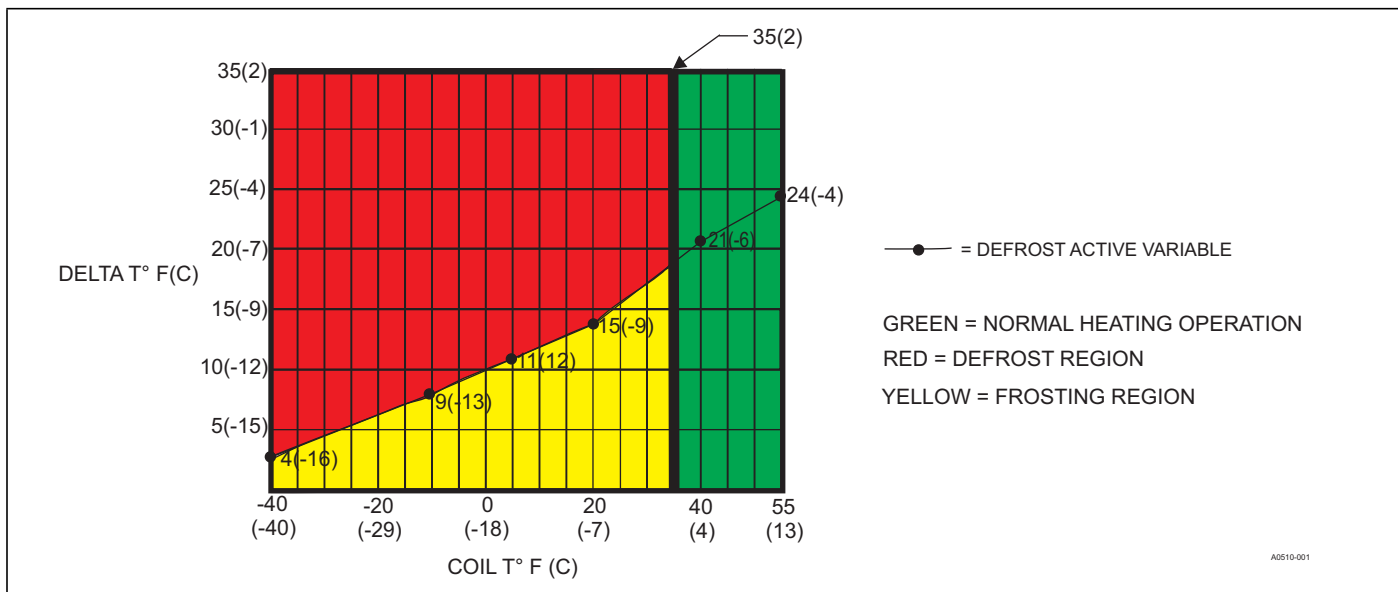

FIGURE 14: Defrost Operation Curves (Variables - Defrost Active Variable)

#### Defrost Mode

The defrost mode is equivalent to the cooling mode except that the outdoor fan motor is de-energized.

If the call for heating is removed from the control during the defrost cycle, the control terminates the defrost cycle. The control also stops the “Defrost Cycle Timer,” but the control does not reset the “Defrost Cycle Timer.” If conditions requiring defrost remain (coil temperature is below 35° F) and the control receives another call for compressor heating and then the call for heating is removed, the system restarts the defrost cycle and the “Defrost Cycle Timer.”

The control remembers in what stage and in what part of the control operation it is before initiating a defrost. The control runs 4<sup>th</sup> Stage compressor during defrost operation and during calibration.

The control does the following to initiate a defrost cycle.

- Communicate proper speed of compressor (High Stage – 4<sup>th</sup> Stage)
- The Low Pressure Switch (LPS) is ignored during defrost.
- Begin the “Defrost Cycle Timer”
- De-energize the outdoor fan
- Energize the reversing valve
- Energize “Y2 OUT” for high ID airflow (if not already active)
- Energize “W1 OUT” for auxiliary heat and “W2 OUT” 15 minutes following “W1 OUT” being energized.



## Defrost Termination

The control terminates the defrost cycle immediately after the coil temperature goes above the selected termination temperature 50° F, 60° F, 70° F, or 80° F for 2 seconds. This selection is made per a shunt jumper on the control board. If the terminate temperature selection shunt jumper is not installed or more than one setting recognized, 50° F becomes the default termination temperature. The coil temperature used to terminate the defrost cycle may be filtered to improve the performance of the system.

Once a defrost mode is initiated, an internal timer (Defrost Cycle Timer) counts the time that the defrost mode is engaged and that the compressor is energized. After 12 minutes of operation in the defrost mode, the defrost sequence terminates immediately and resets the internal timings regardless of the state of the coil sensor temperature.

Once a defrost mode is initiated, an internal timer (Coil T greater than 35° F Timer) counts the time that the coil temperature Coil T is above 35° F. The control is able to indicate at the end of a defrost if the Coil T is or is not more than 35° F for 4 minutes. If the control determines that it was above 35° F for longer than 4 minutes and the control terminates the defrost based on the Defrost Cycle Timer, the control accepts that the coil is frost free, and it remains or enters the Demand Defrost Mode and calibrates for the next defrost. If the control determines that it is not above 35° F for more than 4 minutes and the control terminates the defrost based on the Defrost Cycle Timer, the control accepts that the coil is NOT frost free, and it remains or enters the Time/Temperature Defrost Mode.

The control immediately terminates a forced defrost cycle once forced by shorting the TEST input when the "O" input is energized. This allows the run test equipment to reduce the time required for production testing. The control does not terminate a normal defrost cycle if it receives an "O" signal during the defrost cycle.

The Low Pressure Switch is ignored during defrost and for 120 seconds following termination of a Defrost.

The control establishes a new Dry Coil Delta T following termination of this defrost cycle. The compressor run time resets when the defrost cycle is complete.

Before returning to the previous compressor speed and to the same place in the system starting operation when exiting defrost, the control waits until after calibration and the next defrost is completed. The control does NOT de-energize the "Y2 OUT" for the high ID airflow until after the calibration is completed (unless required by the presents of a heating call).

The control does the following to terminate a defrost cycle.

- De-energize the reversing valve  
Wait 5 seconds
- Lower compressor speed to 2<sup>nd</sup> stage
- Energize outdoor fan (which communicates the proper speed).  
Wait 30 seconds
- Ramp compressor speed to 4<sup>th</sup> stage  
Wait 5 minutes
- Take 4 readings starting on the 5<sup>th</sup> minute
- The Low Pressure Switch is ignored for 120 seconds following termination of a defrost.
- Communicate proper speed of compressor (previous speed before defrost, after calibration)
- Clear the maximum "Defrost Cycle Timer"
- De-energize "Y2 OUT" for high ID airflow (unless required by heating call present, after calibration)
- De-energize the auxiliary heat outputs (unless required by heating call present)
- Reset and restart defrost inhibit timer

## COOLING OPERATING ENVELOPE THRESHOLD ERRORS

The control operates the compressor and outdoor fan with temperature limitations and toggles between current commanded speed and threshold error. If an anti-short cycle delay (ASCD) timer is currently active during any of the below events, it continues in the background and the system starts after the ASCD timer is satisfied. The errors are cleared when the outdoor ambient temperature is within the operating ambient envelope. Threshold errors include the following:

- Outdoor ambient temperature between 109° F – 125° F (cooling operation)
- Outdoor ambient temperature greater than 125° F (cooling operation)
- Outdoor ambient temperature less than 35° F (low ambient temperature cooling operation)

In the event ambient conditions exceed 125°F, the inverter drive may enter into a software/protection condition. This can cause the system to halt operation in order to protect hardware.

### Cooling Operation

During cooling operation, the control receives thermostat signals at the "Y1" and/or "Y2" and "O" input terminals. The control communicates the proper compressor speed and OD fan speed to the inverter drive, based on the control operation. The control energizes the "RV" and "RVG" terminals with 24VAC to switch the reversing valve.

Upon a power cycle or initial power up, the system enters 4<sup>th</sup> Stage (Nominal). If the outdoor ambient temperature is less than 110° F (dependent on compressor run time), the system stages to the 5<sup>th</sup> Stage (Over Drive). When the call for conditioning is removed, the system stores an exit comparison based on compressor run time and last stage of operation. With a new call for conditioning, the system uses the previously calculated exit comparison with the new active thermostat call (Y1 + O) or calls (Y1 + Y2 + O) to determine the next stage of operation. Detailed information pertaining to System Staging can be found in the Operation Manual.

### Low Ambient Temperature Cooling Operation

Low ambient cooling will only function in Normal Operating Mode "N" between 35° F – 60° F. As ambient temperatures decrease, compressor will maintain Nominal RPM speed and the Outdoor Fan RPM will modulate to maintain a constant discharge temperature to stabilize the system pressures.

## HEATING OPERATION

During heating operation, the control receives thermostat signals at the "Y1" and/or "Y2" input terminals. The control communicates the proper compressor speed and OD fan speed to the inverter drive, based on the control operation.

Upon a power cycle or initial power up, the system enters 4<sup>th</sup> Stage (Nominal). If the outdoor ambient temperature is greater than -5° F (dependent on compressor run time), the system stages to the 5<sup>th</sup> Stage (Over Drive). When the call for conditioning is removed the system stores an exit comparison based on compressor run time and last stage of operation. With a new call for conditioning, the system uses the previously calculated exit comparison with the new active thermostat call (Y1) or calls (Y1 + Y2) to determine the next stage of operation. Detailed information pertaining to System Staging can be found in the Operation Manual.

## Emergency Heat

Emergency Heating mode is defined as a compressor speed reference of zero and the backup heat source energized. In other words, a 'W' signal present without any 'Y' signals present. The control energizes 'W1 OUT' immediately when an emergency heat signal "W" is received. The control energizes "W2 OUT" 15 minutes after the "W1 OUT" output is energized.

During emergency heating mode, the control returns to standby mode. The control passes the "W1 OUT" back to the ID unit automatically if no "Y" is present. The reason is that "W" and "W1 OUT" are connected via a normally closed relay contact.

## PRESSURE SWITCH FAULT & LOCKOUT

### High Pressure Switch (HPS) Fault

If the compressor is operating and the high pressure switch is recognized as open, the control de-energizes the compressor output (and the defrost outputs if they are active). The 5 minute ASCD timer starts when the compressor speed reaches 0. The compressor contactor remains off until the high pressure switch has re-closed and the 5 minute ASCD timer has been satisfied.

If the coil (liquid line) temperature conditions allow defrost to occur when the control continues the call for heating, the control restarts the defrost cycle and the timer at the point the call for heating is interrupted.

### High Pressure Switch Lockout

If the control recognizes two HPS faults within six hours of accumulated compressor run-time, the control enter the HPS soft lockout. During the lockout period, the defrost and compressor relays remain de-energized. While the control is locked out, the STATUS LED flashes the appropriate code as described in Table 8 and indicates the fault that caused the lockout condition. Refer to Table 8 for fault code definitions. The control differentiates between PS faults that occur in heating or defrost modes. This enables the control to decide which fault code to display. This can assist the technician in troubleshooting issues with the unit when this lockout occurs. Otherwise it does not differentiate between heating or defrost modes when counting PS faults.

The six hour timing starts after the ASCD has expired following the first PS fault. The timer only accumulates when the compressor is running. If the control recognizes a second opening of the PS before the six hour timer expires, the control enters the PS soft lockout. If the control does not recognize a second opening of the PS before the six hour timer expires, the six hour timer is cleared and the PS fault counter is reset.

If the system detects four HPS lockouts (a total of eight HPS openings) within a twelve-hour period, the system enters a hard lockout condition from which power is needed to cycle for restoration of system function. Shorting the TEST pins for more than two seconds resets the lock as well.

### Low Pressure Switch (LPS) Fault

During defrost operation; the control ignores the low-pressure switch (LPS) input. If the LPS opens during defrost operation, the control does not consider this to be a LPS fault. The control also ignores the LPS input for the first 120 seconds of compressor operation and for 120 seconds following the completion of a defrost cycle. It also ignores the LPS input while the TEST input is shorted and any "Y" input ("Y1" or "Y2") is energized. The control ignores the LPS input when the outdoor ambient temperature is less than 15° F. This prevents LPS lockouts while the unit is operating in heating mode during extreme cold conditions. The discharge temperature sensor continues to provide loss of charge protection.

If the LPS opens for more than five seconds under conditions that the control is not ignoring the LPS input, the control enters a soft lockout mode. If four LPS openings occur within a twelve-hour period, it causes a hard lockout which can be reset by cycling system power, or by shorting the TEST pins for more than 2 seconds.

## HOT HEAT PUMP MODE (All Models)

If the compressor is in 3<sup>rd</sup> stage and the hot heat pump jumper is in the ON position, the control can not output 24 VAC on "Y2 OUT."

If the compressor is in 3<sup>rd</sup> stage and the hot heat pump jumper is in the OFF position, the control outputs 24 VAC on "Y2 OUT."

### Reduced Airflow Feature

The reduced airflow feature operates only if the "HOT HEAT PUMP" jumper on the heat pump main control is placed in the "ON" position. The "Y2 OUT" signal must also be connected to the indoor unit for this feature to function properly.

The Reduced Airflow Feature creates the Hot Heat Pump by controlling the indoor airflow level during heating operation only. The cooling operation is not affected. The control changes the indoor airflow level using the "Y2 OUT" signal terminal. The "Y2 OUT" terminal connects to the high speed cooling input of a variable speed indoor unit. When the heat pump control energizes the "Y2 OUT" terminal, the indoor blower runs at high speed delivering high airflow.

When the control de-energizes the "Y2 OUT" terminal, the indoor airflow level reduces as the blower runs at a lower speed delivering lower airflow and higher leaving air temperature.

## SECTION XI: INSTRUCTING THE OWNER

Assist owner with processing warranty cards and/or online registration. Review Owners Guide and provide a copy to the owner and guidance on proper operation and maintenance. Instruct the owner or the operator how to start, stop and adjust temperature setting.

When applicable, instruct the owner that the compressor is equipped with a crankcase heater to prevent the migration of refrigerant to the compressor during the OFF cycle. The heater is energized only when the unit is not running. If the main switch is disconnected for long periods of shut down, do not attempt to start the unit until 2 hours after the switch has been connected. This will allow sufficient time for all liquid refrigerant to be driven out of the compressor.

The installer should also instruct the owner on proper operation and maintenance of all other system components.

## MAINTENANCE

1. Dirt should not be allowed to accumulate on the outdoor coils or other parts in the air circuit. Clean as often as necessary to keep the unit clean. Use a brush, vacuum cleaner attachment, or other suitable means.
2. The outdoor fan motor bearings are permanently lubricated and do not require periodic oiling.
3. If the coil needs to be cleaned, it should be washed with a PH neutral detergent. Allow solution to remain on coil for several minutes before rinsing with clean water. Solution should not be permitted to come in contact with painted surfaces.
4. Refer to the furnace or air handler instructions for filter and blower motor maintenance.
5. The indoor coil and drain pan should be inspected and cleaned regularly to prevent odors and assure proper drainage.

## CAUTION

*It is unlawful to knowingly vent, release or discharge refrigerant into the open air during repair, service, maintenance or the final disposal of this unit.*

**COOLING CHARGE TABLE IS ON THE INSIDE OF THE CONTROL BOX COVER.**

SECTION XII: WIRING DIAGRAM

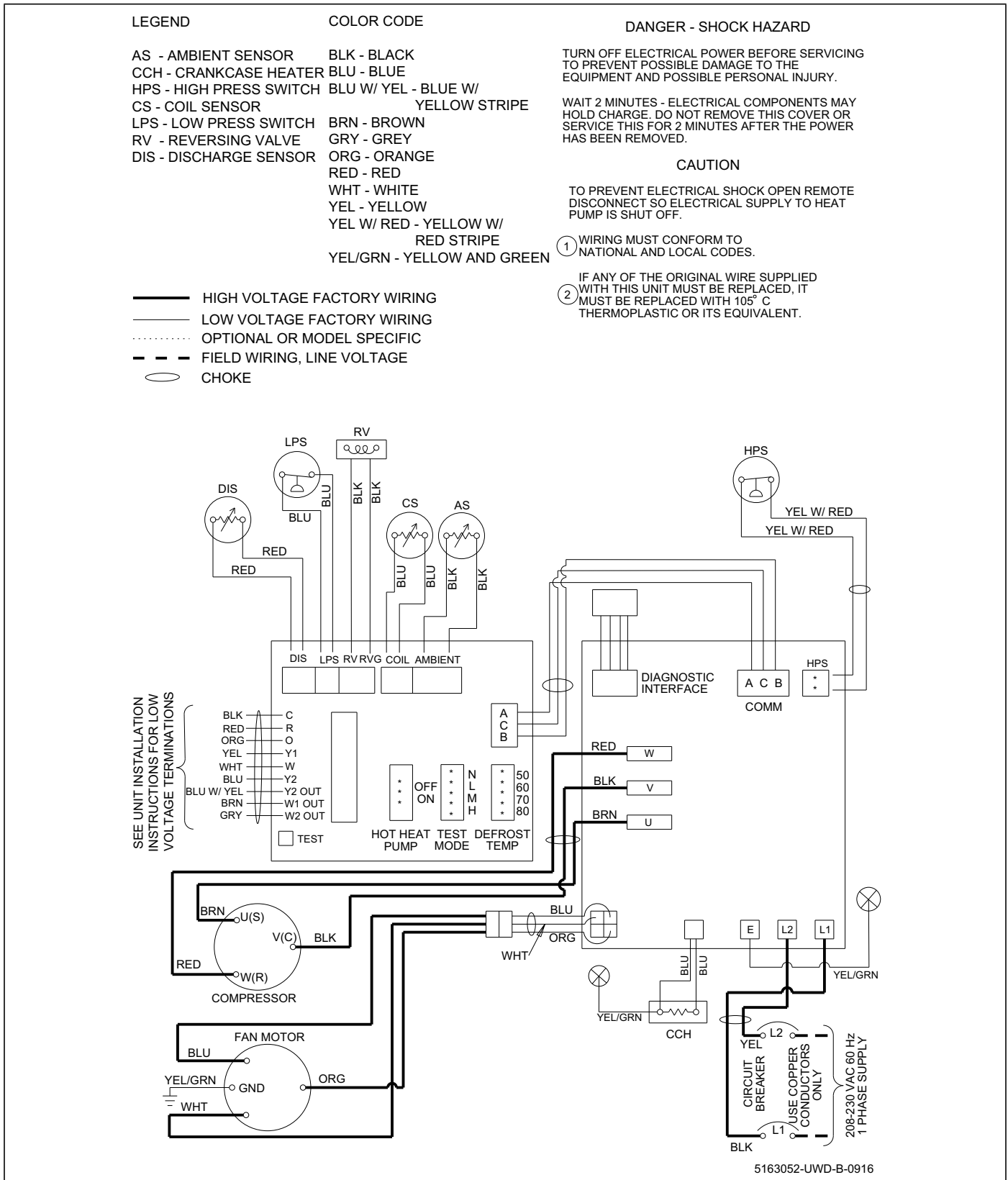

FIGURE 15: Wiring Diagram - Single Phase (Demand Defrost)

## NOTES

## SECTION XIII: START UP SHEET

## Modulating Heat Pump and Supplementary Heat Start-Up Sheet

Proper start-up is critical to customer comfort and equipment longevity

Start-Up Date Technician Performing Start-Up Installing Contractor Name **Owner Information**Name Address City State or Province Zip or Postal Code Elevation above sea level **Equipment Data** Upflow Downflow Horizontal Left Horizontal RightIndoor Unit Model # Indoor Unit Serial # Indoor Coil Model # Indoor Coil Serial # Outdoor Unit Model # Outdoor Unit Serial # **Filter, Thermostat, Accessories**Filter Type Filter Size Filter Location(s) Thermostat Type Other System Equipment and Accessories **Connections -- Per Installation Instructions and Local Codes**

- Unit is level     Supply plenum and return ducts are connected and sealed     Refrigerant piping complete and leak tested  
 Gas piping is connected (if applicable)     Vent system is connected (if applicable)  
 Condensate drain for indoor coil properly connected     Condensate drain for furnace (if applicable)

**Electrical: Line Voltage**Indoor unit (volts AC) Outdoor unit (volts AC) Overcurrent Protection Breaker / Fuses Amperes 

- Ground wire is connected     Polarity is correct (120vac indoor units) black is L1 (hot), white is N (neutral)

**Electrical: Low Voltage**  Thermostat wiring complete

- Heat anticipator is set to the recommended value listed in the Installation Instructions

Heat anticipator  
recommended value Low voltage values: "R" and "C" at Indoor unit control board (volts AC) "R" and "C" Outdoor unit control board (volts AC) **Supplementary Heating Set-Up**Heating Type  Electric Air Handler     Natural Gas     LP Gas (Requires LP Conversion Kit)Inlet Gas Pressure (in. w.c.) Manifold Gas Pressure (in. w.c.) LP Gas Conversion Kit Part # Used Calculated input in btuh - clock the gas meter (Nat Gas Only) LP Kit Installed By Electric Heat Kit Part # (if applicable) KW installed Rated BTU/H (furnaces) **Venting (if applicable)**

- Venting system properly sized, within the limitations of the charts in the installation instructions.

Intake Size # of 90 Degree Ells # of 45 Degree Ells Length Exhaust Size # of 90 Degree Ells # of 45 Degree Ells Length

### Air Side: System Total External Static Pressure

Supply static before indoor coil (in w.c.)	<input type="text"/>	Supply static after indoor coil (in w.c.)	<input type="text"/>
Return Static (in w.c.) before filter	<input type="text"/>	Return Static (in w.c.) after filter (furnace side)	<input type="text"/>
Total External Static Pressure	<input type="text"/>	Maximum Rated ESP (in w.c.)	<input type="text"/>

<b>Cooling &amp; Heat Pump Indoor Blower Set-Up</b>	<input type="radio"/> VARIABLE ECM	COOL	<input type="radio"/> A	<input type="radio"/> B	<input type="radio"/> C	<input type="radio"/> D	
		ADJUST	<input type="radio"/> A	<input type="radio"/> B	<input type="radio"/> C	<input type="radio"/> D	
		DELAY	<input type="radio"/> A	<input type="radio"/> B	<input type="radio"/> C	<input type="radio"/> D	
	<input type="radio"/> Standard ECM		<input type="radio"/> 1	<input type="radio"/> 2	<input type="radio"/> 3	<input type="radio"/> 4	<input type="radio"/> 5
Return Air: <input type="text"/>	Wet Bulb <input type="text"/>	Supply Air: <input type="text"/>	Wet Bulb <input type="text"/>	Temperature Drop <input type="text"/>	Outside Air: <input type="text"/>	Dry Bulb <input type="text"/>	

<b>Supplementary Heating Indoor Blower Set-Up</b>	<input type="radio"/> VARIABLE ECM	HEAT	<input type="radio"/> A	<input type="radio"/> B	<input type="radio"/> C	<input type="radio"/> D	
			<input type="radio"/> 1	<input type="radio"/> 2	<input type="radio"/> 3	<input type="radio"/> 4	<input type="radio"/> 5
	<input type="radio"/> Standard ECM						
Return Air: <input type="text"/>	Wet Bulb <input type="text"/>	Supply Air: <input type="text"/>	Wet Bulb <input type="text"/>	Temperature Rise <input type="text"/>			

**Heat Pump Main Control Board**

Fill in the information i.e.. "ON", "OFF" or the appropriate "Value" for the fields that apply to the defrost control board installed

Hot Heat Pump  Yes or  No

Defrost Temperature  50  60  70  80

**Refrigerant Charge and Indoor Metering Device**

R-410A  TXV

Additional Lineset Length  Adder per foot - lbs.  Oz.

Lineset Size  Liquid  Suction

# Elbows  # 45s  Total Added - lbs.  Oz.

Liquid Line Temp  High Side Pressure  Suction Line Temp  Low Side Pressure

TXV #  Indoor Subcooling  Indoor Superheat

**Cycle Test**

Operate the unit through several heating cycles from the thermostat, noting and correcting any problems

Operate the unit through continuous fan cycles from the thermostat, noting and correcting any problems

Operate the unit through a cooling cycles, noting and correcting any problems

Operate the unit through an emergency heating cycles, noting and correcting any problems

**Clean Up**

Installation debris disposed of and indoor and outdoor areas cleaned up?

**Owner Education**

Provide owner with the owner's manual

Explain operation of system to equipment owner

Explain thermostat use and programming (if applicable) to owner

Explain the importance of regular filter replacement and equipment maintenance

**Comments Section**