

INSTALLATION MANUAL

R-410A OUTDOOR SPLIT-SYSTEM HEAT PUMP

MODELS: 14 SEER -
YHE, TH4, THE, RHP14L SERIES
1.5 TO 5 TONS – 1 & 3 PHASE



LIST OF SECTIONS

GENERAL	1	ELECTRICAL CONNECTIONS	13
SAFETY	1	SYSTEM START-UP	14
UNIT INSTALLATION	2	SYSTEM OPERATION	15
INDOOR EXPANSION DEVICE	5	INSTRUCTING THE OWNER	18
EVACUATION	6	WIRING DIAGRAM	19
SYSTEM CHARGE	6	START UP SHEET	23

LIST OF FIGURES

Typical Installation	3	Outdoor Unit Control Box (208/230V & 460V 3-Phase)	13
Installation of Vapor Line	4	Typical Field Wiring (Air Handler / Electrical Heat) (Single and Three-Phase)	14
Underground Installation	4	Heat Pump Flow Diagram	15
Heat Protection	5	Demand Defrost Control Module	16
TXV Installation	6	Defrost Operation Curves	17
TXV Bulb and Equalizer Line Installations	6	Wiring Diagram - Single Phase - 208/230V (Demand Defrost)	19
Proper Bulb Location	6	Wiring Diagram - Three Phase - 208/230V (Demand Defrost)	20
Outdoor Unit Swing Away Control Box	13	Wiring Diagram - Three Phase - 460V (Demand Defrost)	21
Outdoor Unit Control Box (208/230V Single Phase)	13		

LIST OF TABLES

Maximum / Minimum Operating Limit Conditions 2		YHE42 Heat Charging Charts	11
R-410A Saturation Properties	7	YHE48 Heat Charging Charts	11
YHE18 Heat Charging Charts	8	YHE60 Heat Charging Charts	12
YHE24 Heat Charging Charts	8	TEST Input Functionality with Y	15
YHE30 Heat Charging Charts	9	TEST Input Functionality without Y	15
YHE35 Heat Charging Charts	9	Status Code Display	16
YHE36 Heat Charging Charts	10	Status	16

SECTION I: GENERAL

The outdoor units are designed to be connected to a matching indoor coil with sweat connect lines. Sweat connect units are factory charged with refrigerant for a nominal sized matching indoor coil plus 15 feet of field-supplied lines.

Matching indoor coils can be used with a thermostatic expansion valve (TXV). Refer to the Tabular Data Sheet or to the Technical Guide for the proper selection.

SECTION II: SAFETY



This is a safety alert symbol. When you see this symbol on labels or in manuals, be alert to the potential for personal injury.

Understand and pay particular attention to the signal words **DANGER**, **WARNING**, or **CAUTION**.

DANGER indicates an **imminently** hazardous situation, which, if not avoided, **will result in death or serious injury**.

WARNING indicates a **potentially** hazardous situation, which, if not avoided, **could result in death or serious injury**.

CAUTION indicates a potentially hazardous situation, which, if not avoided **may result in minor or moderate injury**. It is also used to alert against unsafe practices and hazards involving only property damage.

▲ WARNING

Improper installation may create a condition where the operation of the product could cause personal injury or property damage.

Improper installation, adjustment, alteration, service or maintenance can cause injury or property damage. Refer to this manual for assistance or for additional information, consult a qualified contractor, installer or service agency.

⚠ CAUTION

This product must be installed in strict compliance with the enclosed installation instructions and any applicable local, state, and national codes including, but not limited to building, electrical, and mechanical codes.

⚠ CAUTION

*R-410A systems operate at higher pressures than R-22 systems. Do not use R-22 service equipment or components on R-410A equipment. Service equipment **Must Be Rated** for R-410A.*

INSPECTION

As soon as a unit is received, it should be inspected for possible damage during transit. If damage is evident, the extent of the damage should be noted on the carrier's delivery receipt. A separate request for inspection by the carrier's agent should be made in writing. See Local Distributor for more information.

Requirements For Installing/Serviceing R-410A Equipment

- Gauge sets, hoses, refrigerant containers, and recovery system must be designed to handle the POE type oils, and the higher pressures of R-410A.
- Manifold sets should be high side and low side with low side retard.
- All hoses must have a 700 psig service pressure rating.
- Leak detectors should be designed to detect HFC refrigerant.
- Recovery equipment (including refrigerant recovery containers) must be specifically designed to handle R-410A.
- Do not use an R-22 TXV.

LIMITATIONS

The unit should be installed in accordance with all National, State and Local Safety Codes and the limitations listed below:

1. Limitations for the indoor unit, coil, and appropriate accessories must also be observed.
2. The outdoor unit must not be installed with any duct work in the air stream. The outdoor fan is the propeller type and is not designed to operate against any additional external static pressure.
3. The maximum and minimum conditions for operation must be observed to ensure a system that will give maximum performance and service life.

TABLE 1: Maximum / Minimum Operating Limit Conditions

AIR TEMPERATURE AT OUTDOOR COIL, °F				AIR TEMPERATURE AT INDOOR COIL, °F			
Min.		Max.		Min.		Max.	
DB Cool	DB Heat	DB Cool	DB Heat	WB Cool	DB Heat	WB Cool	DB Heat
50° F	-10° F	125° F	75° F	57° F	50° F	72° F	80° F
Operation below this temperature is permissible for a short period of time, during morning warm-up.							

4. The unit should not be operated in cooling mode at outdoor temperatures below 50° F without an approved low ambient operation accessory kit installed.
5. The maximum allowable line length for this product is 80 feet. To install more than the maximum allowable line length, consult the Piping Application Guide (P/N 247077).

SECTION III: UNIT INSTALLATION**LOCATION**

Before starting the installation, select and check the suitability of the location for both the indoor and outdoor unit. Observe all limitations and clearance requirements.

The outdoor unit must have sufficient clearance for air entrance to the condenser coil, air discharge, and service access. See Figure 1.

NOTICE

For multiple unit installations, units must be spaced a minimum of 24" (61 cm) apart (coil face to coil face).

If the unit is to be installed on a hot sun exposed roof or a paved ground area that is seasonally hot, the unit should be raised sufficiently above the roof or ground to avoid taking the accumulated layer of hot air into the outdoor unit.

If the system is being installed during seasonally cold weather of 55° F or below, the preferred method is to weigh in the charge. For charging or checking the system charge at 55° F or below, refer to the "Optional Cold Weather Charging" procedures near the end of SECTION VI: SYSTEM CHARGE. There is an "Optional Cold Weather Charging" accessory kit to prevent the outdoor unit from taking in cold air below 55° F. The kit part number can be found in the list of accessory kits on the UPGNET web site.

Provide adequate structural support for the unit.

ADD-ON REPLACEMENT/RETROFIT

When this unit is being used as a replacement for an R-410A unit, it is required that the outdoor unit, indoor coil, and metering device all be replaced. The following steps should be performed in order to insure proper system operation and performance. Line-set change out is also recommended.

1. Change-out of the indoor coil to an approved R-410A coil/ condensing unit combination with the appropriate metering device.
2. Change-out of the line-set when replacing an R-22 unit with an R410-A unit is highly recommended to reduce cross-contamination of oils and refrigerants.
3. If change-out of the line set is not practical, then the following precautions should be taken.
 - Inspect the line set for kinks, sharp bends, or other restrictions, and for corrosion.
 - Determine if there are any low spots which might be serving as oil traps.
 - Flush the line set with a commercially available flush kit to remove as much of the existing oil and contaminants as possible.
 - Install a suction line filter-drier to trap any remaining contaminants, and remove after 50 hours of operation.
4. If the outdoor unit is being replaced due to a compressor burnout, then installation of a 100% activated alumina suction-line filter drier in the suction-line is required, in addition to the factory installed bi-flow liquid-line drier. Operate the system for 10 hours. Monitor the suction drier pressure drop. If the pressure drop exceeds 3 psig, replace both the suction-line and liquid-line driers. After a total of 10 hours run time where the suction-line pressure drop has not exceeded 3 psig, replace the liquid line drier, and remove the suction-line drier. Never leave a suction-line drier in the system longer than 50 hours of run time.

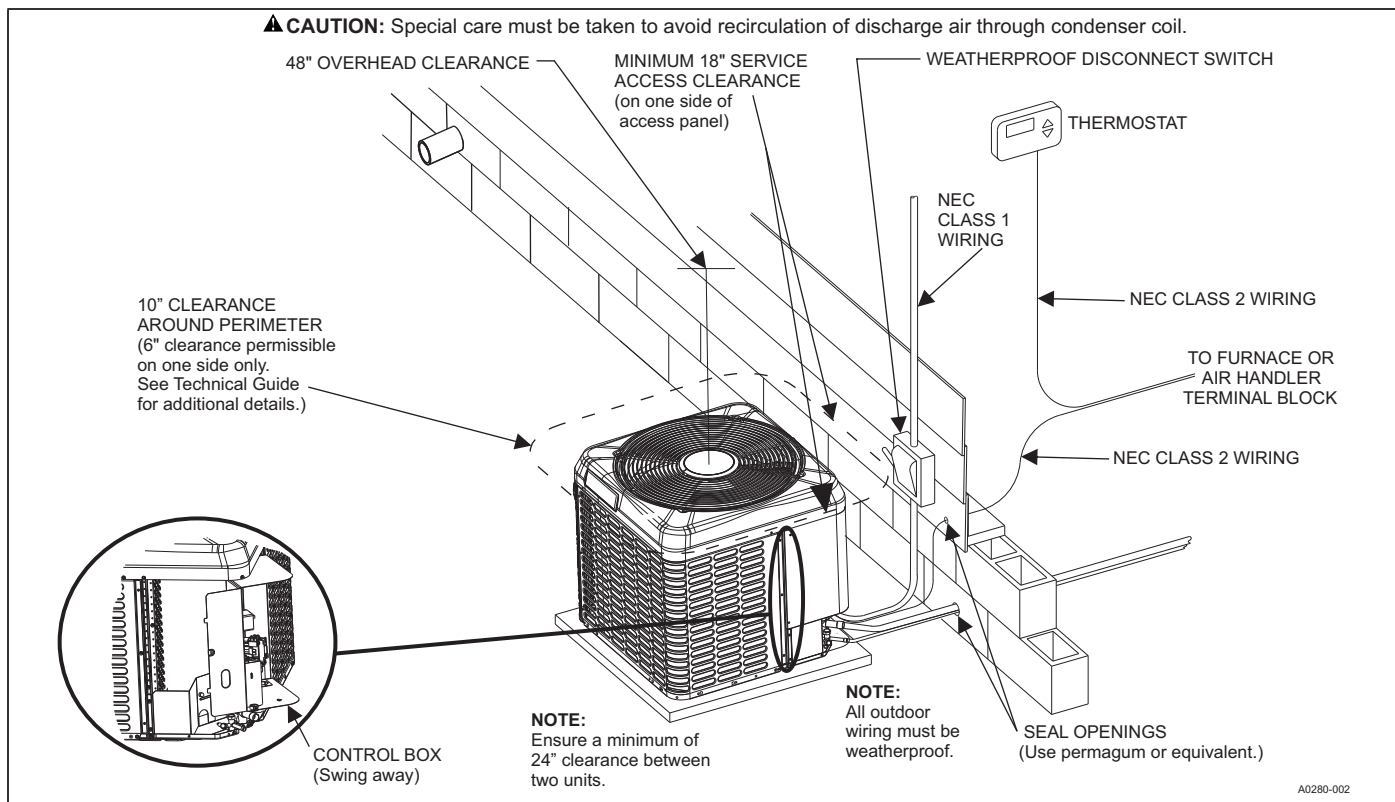

FIGURE 1: Typical Installation

GROUND INSTALLATION

The unit may be installed at ground level on a solid base that will not shift or settle, causing strain on the refrigerant lines and possible leaks. The unit must be installed in as level a position as possible while maintaining the clearances shown in Figure 1.

Normal operating sound levels may be objectionable if the unit is placed directly under windows of certain rooms (bedrooms, study, etc.).

Condensate will drain from beneath the coil of the outdoor unit during the defrost cycle. Normally this condensate may be allowed to drain directly on the ground.

⚠ WARNING

The outdoor unit should not be installed in an area where mud or ice could cause personal injury. Remember that condensate will drip from the unit coil during heat and defrost cycles and that this condensate will freeze when the temperature of the outdoor air is below 32°F.

Elevate the unit sufficiently to prevent any blockage of the air entrances by snow in areas where there will be snow accumulation. Check the local weather bureau for the expected snow accumulation in your area. Isolate the unit from rain gutters to avoid any possible wash out of the foundation.

ROOF INSTALLATION

When installing units on a roof, the structure must be capable of supporting the total weight of the unit, including a pad, lintels, rails, etc., which should be used to minimize the transmission of sound or vibration into the conditioned space.

WALL MOUNT INSTALLATION

Care must be taken to mount the outdoor unit on a solid base that is sloped to shed water, secure from settlement, and is isolated from the structural foundation or walls to prevent sound and vibration transmission into the living space.

On occasion, site conditions may require direct wall mounted brackets to be used to locate and support the outdoor unit. In these applications, care must be taken to address unit base pan support, structural integrity, safe access and serviceability, as well as the possible sound and vibration transmission into the structure. These applications are best served by a properly engineered solution.

UNIT PLACEMENT

NOTICE

Heat pumps will defrost periodically resulting in water drainage. The unit should not be located where water drainage may freeze and create a hazardous condition - such as sidewalks and steps.

1. Provide a base in the pre-determined location.
2. Remove the shipping carton and inspect for possible damage.
3. Ensure that compressor tie-down bolts remain tightened.
4. Position the unit on the base provided.

LIQUID LINE FILTER-DRIER

The heat pumps have a solid core bi-flow filter/drier located on the liquid line.

⚠ CAUTION

Failure to use the same as the original factory drier or using a substitute drier or a granular type may result in damage to the equipment.

NOTICE

Replacements for the liquid line drier must be exactly the same as marked on the original factory drier. See Source 1 for O.E.M. replacement driers.

R-410A Filter-Drier Source 1 Part No.	Apply with Models
S1-52636219000	All

PIPING CONNECTIONS

The outdoor condensing unit must be connected to the indoor evaporator coil using field supplied refrigerant grade (ACR) copper tubing that is internally clean and dry. Units should be installed only with the tubing sizes for approved system combinations as specified in tabular data sheet. The charge given is applicable for total tubing lengths up to 15 feet (4.6 m). See Piping Application Guide (P/N 247077) for installing tubing of longer lengths and elevation differences.

NOTICE

Using a larger than specified line size could result in oil return problems. Using too small a line will result in loss of capacity and other problems caused by insufficient refrigerant flow. Slope horizontal vapor lines at least 1" (2.5 cm) every 20 feet (6.1 m) toward the outdoor unit to facilitate proper oil return. If more than the 75 foot line length is necessary, facilitate proper refrigerant velocity with adjusted line diameter in accordance with the Piping Application Guide (P/N 247077).

CAUTION

This system uses R-410A refrigerant which operates at higher pressures than R-22. No other refrigerant may be used in this system. Gauge sets, hoses, refrigerant containers, and recovery system must be designed to handle R-410A. If you are unsure, consult the equipment manufacturer.

WARNING

Never install a suction-line filter drier in the liquid line of an R-410A system. Failure to follow this warning can cause a fire, injury or death.

PRECAUTIONS DURING LINE INSTALLATION

1. Install the lines with as few bends as possible. Care must be taken not to damage the couplings or kink the tubing. Use clean hard drawn copper tubing where no appreciable amount of bending around obstruction is necessary. If soft copper must be used, care must be taken to avoid sharp bends which may cause a restriction.
2. The lines should be installed so that they will not obstruct service access to the coil, air handling system, or filter.
3. Care must also be taken to isolate the refrigerant lines to minimize noise transmission from the equipment to the structure.
4. The vapor line must be insulated with a minimum of 1/2" foam rubber insulation (Armaflex or equivalent). Liquid lines that will be exposed to direct sunlight, high temperatures, or excessive humidity must also be insulated.
5. Tape and suspend the refrigerant lines as shown. DO NOT allow tube metal-to-metal contact. See Figure 2.
6. Use PVC piping as a conduit for all underground installations as shown in Figure 3. Buried lines should be kept as short as possible to minimize the build up of liquid refrigerant in the vapor line during long periods of shutdown.

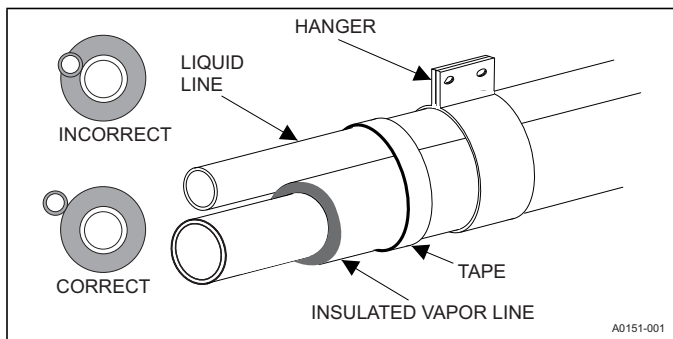

FIGURE 2: Installation of Vapor Line

7. Pack fiberglass insulation and a sealing material such as perma-gum around refrigerant lines where they penetrate a wall to reduce vibration and to retain some flexibility.
8. For systems with total line length exceeding 75 feet (22.86 m), see Piping Application Guide (P/N 247077) for vapor and liquid line sizing, calibration of liquid line pressure loss or gain, determination of vapor line velocity, elevation limitations, TXV connections, system charging, traps, etc.

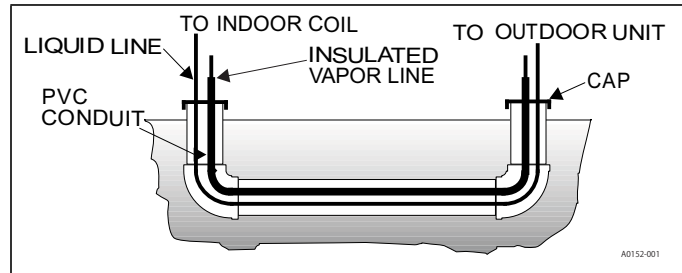

FIGURE 3: Underground Installation

PRECAUTIONS DURING BRAZING OF LINES

All outdoor unit and evaporator coil connections are copper-to-copper and should be brazed with a phosphorous-copper alloy material such as Silfos-5 or equivalent. DO NOT use soft solder. The outdoor units have reusable service valves on both the liquid and vapor connections. The total system refrigerant charge is retained within the outdoor unit during shipping and installation. The reusable service valves are provided to evacuate and charge per this instruction.

Serious service problems can be avoided by taking adequate precautions to assure an internally clean and dry system.

CAUTION

Dry nitrogen should always be supplied through the tubing while it is being brazed, because the temperature required is high enough to cause oxidation of the copper unless an inert atmosphere is provided. The flow of dry nitrogen should continue until the joint has cooled. Always use a pressure regulator and safety valve to insure that only low pressure dry nitrogen is introduced into the tubing. Only a small flow is necessary to displace air and prevent oxidation.

PRECAUTIONS DURING BRAZING SERVICE VALVE

Precautions should be taken to prevent heat damage to service valve by wrapping a wet rag around it as shown in Figure 4. Also, protect all painted surfaces, insulation, and plastic base during brazing. After brazing, cool joint with wet rag.

WARNING

This is not a backseating valve. The service access port has a valve core. Opening or closing valve does not close service access port. If the valve stem is backed out past the chamfered retaining wall, the O-ring can be damaged causing leakage or system pressure could force the valve stem out of the valve body possibly causing personal injury.

Valve can be opened by removing the service valve cap and fully inserting a hex wrench into the stem and backing out counter-clockwise until valve stem just touches the chamfered retaining wall.

Connect the refrigerant lines using the following procedure:

1. Remove the cap and Schrader core from both the liquid and vapor service valve service ports at the outdoor unit. Connect low pressure nitrogen to the liquid line service port.
2. Braze the liquid line to the liquid valve at the outdoor unit. Be sure to wrap the valve body with a wet rag. Allow the nitrogen to continue flowing.
3. Carefully remove the plugs from the evaporator liquid and vapor connections at the indoor coil.

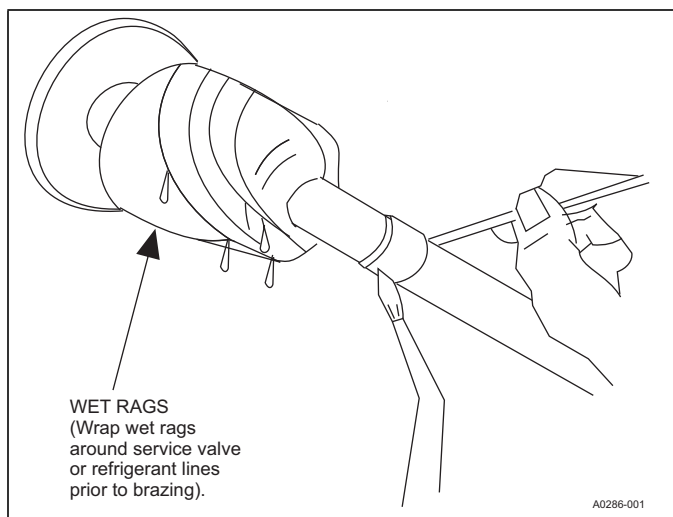

FIGURE 4: Heat Protection

⚠ CAUTION

Do not install any coil in a furnace which is to be operated during the heating season without attaching the refrigerant lines to the coil. The coil is under pressure which must be released to prevent excessive pressure build-up and possible coil damage.

4. Braze the liquid line to the evaporator liquid connection. Nitrogen should be flowing through the evaporator coil.
5. Slide the grommet away from the vapor connection at the indoor coil. Braze the vapor line to the evaporator vapor connection. After the connection has cooled, slide the grommet back into original position.
6. Protect the vapor valve with a wet rag and braze the vapor line connection to the outdoor unit. The nitrogen flow should be exiting the system from the vapor service port connection. After this connection has cooled, remove the nitrogen source from the liquid fitting service port.
7. Replace the Schrader core in the liquid and vapor valves.
8. Go to SECTION IV for TXV installation.
9. Leak test all refrigerant piping connections including the service port flare caps to be sure they are leak tight. **DO NOT OVERTIGHTEN** (between 40 and 60 inch - lbs. maximum).

NOTICE

Line set and indoor coil can be pressurized to 250 psig with dry nitrogen and leak tested with a bubble type leak detector. Then release the nitrogen charge.

Do not use the system refrigerant in the outdoor unit to purge or leak test.

10. Evacuate the vapor line, evaporator, and liquid line to 500 microns or less. See Section V.
11. Replace cap on service ports. Do not remove the flare caps from the service ports except when necessary for servicing the system.

⚠ CAUTION

Do not connect manifold gauges unless trouble is suspected. Approximately 3/4 ounce of refrigerant will be lost each time a standard manifold gauge is connected.

12. Release the refrigerant charge into the system. Open both the liquid and vapor valves by removing the service valve cap and with an allen wrench back out counter-clockwise until valve stem just touches the chamfered retaining wall. If the service valve is a ball valve, use a Crescent wrench to turn valve stem one-quarter turn counterclockwise to open. Do not overturn or the valve stem may break or become damaged. See "PRECAUTIONS DURING BRAZING SERVICE VALVE".
13. Replace service valve cap finger tight, then tighten an additional 1/12 turn (1/2 hex flat). Cap must be replaced to prevent leaks.

⚠ WARNING

Never attempt to repair any brazed connections while the system is under pressure. Personal injury could result.

14. See "System Charge" section for checking and recording system charge. See Section VI.

SECTION IV: INDOOR EXPANSION DEVICE THERMOSTATIC EXPANSION VALVE (TXV) INSTALLATION

⚠ CAUTION

Outdoor unit model numbers ending with an "H" have a factory installed hard start kit which is required when a TXV is installed on the indoor unit. Outdoor unit model numbers with no "H" ending do not require a hard start kit unless a TXV is being installed on the indoor unit or unless local regulations dictate it. The Tabular Data Sheet which comes with the unit specifies whether or not a hard start kit is required. When a TXV Kit is needed, it should be ordered from Source 1.

The following are the basic steps for installation. For detailed instructions, refer to the Installation Instructions accompanying the TXV kit. Install TXV kit as follows:

IMPORTANT

Refer to the Technical Guide for the unit to determine the proper TXV kit to be used on this product.

1. Relieve the holding charge by depressing Schrader core on the suction manifold stub out.
2. After holding charge is completely discharged, loosen and remove the Schrader core.
3. Place a backup wrench on distributor, loosen and remove brass distributor nut. Retain brass nut for use on liquid line. Keep Teflon washer in place and discard clear disk.
4. Install the thermal expansion valve to the distributor assembly with supplied fittings. Ensure Teflon washer is seated in distributor. Hand tighten and turn an additional 1/4 turn to seal. Do not overtighten fittings. See Figure 5.

⚠ CAUTION

Do not overtorque. Do not use slip joint pliers. This will distort the aluminum distributor and the brass fitting (potentially causing leaks).

5. Slide the nut removed in step 3 over the supplied liquid line. Place supplied Teflon washer from TXV kit in place on TXV, and install liquid line to the top of the thermal expansion valve. Adjust assembly so liquid line aligns with hole in access panel. Hand tighten the liquid line, and apply an additional 1/4 turn to seal.

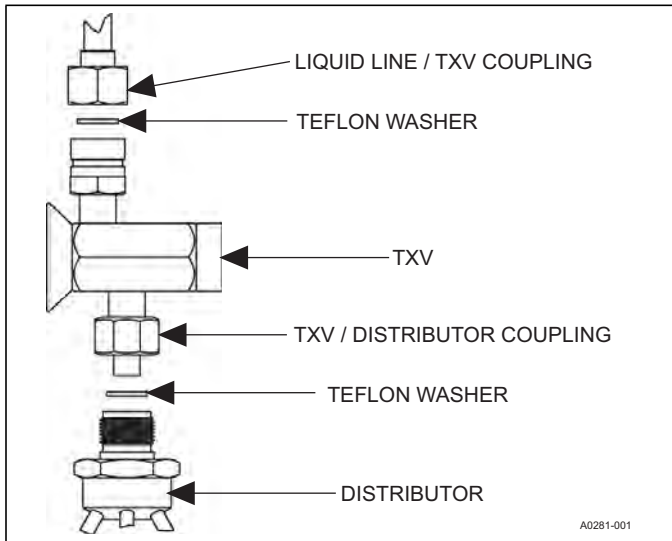

FIGURE 5: TXV Installation

⚠ WARNING

Schrader valve core **MUST NOT** be installed with TXV installation. Poor system performance or system failure could result.

6. Install the TXV equalizer line onto the vapor line by hand tightening the 1/4" SAE coupling nut to the equalizer fitting, and apply an additional 1/3 turn to seal. See Figure 6.

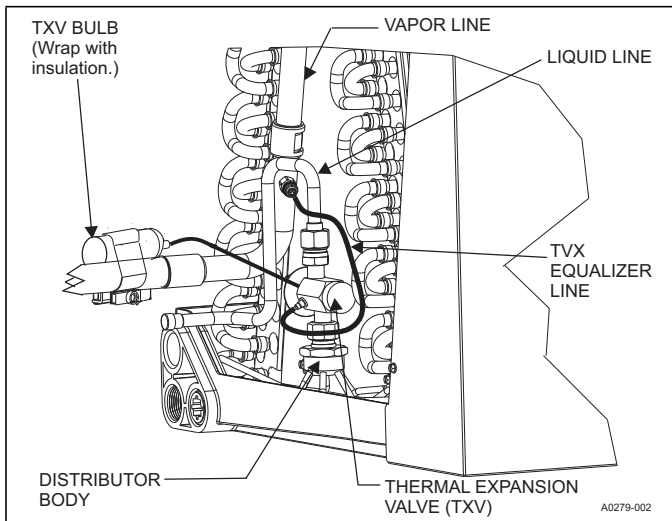

FIGURE 6: TXV Bulb and Equalizer Line Installations

⚠ CAUTION

In all cases, mount the TXV bulb after vapor line is brazed and has had sufficient time to cool. Failure to use suction line grommet may result in premature TXV failure.

7. Pass the TXV temperature sensing bulb through the suction line split grommet in the access panel.
8. Install the TXV bulb to the vapor line near the cabinet, using the bulb clamp(s) furnished with the TXV assembly. Ensure the bulb is making maximum contact. See Figures 6 and 7.
 - a. If possible, install the temperature bulb on a horizontal run of the vapor line. Ensure that the bulb is installed at a 10 o'clock or 2 o'clock position. See Figure 7.

- b. If bulb installation is made on a vertical run, ensure that the bulb is a minimum of 8 inches (20.3 cm) away from elbow coming out of the coil. Position the bulb with the tail of the bulb at the top, so that the bulb acts as a reservoir.
 - c. Insulate the bulb using thermal insulation provided to protect it from the effect of the surrounding ambient temperature. Cover completely to insulate.
9. After line set is installed, leak test the system.

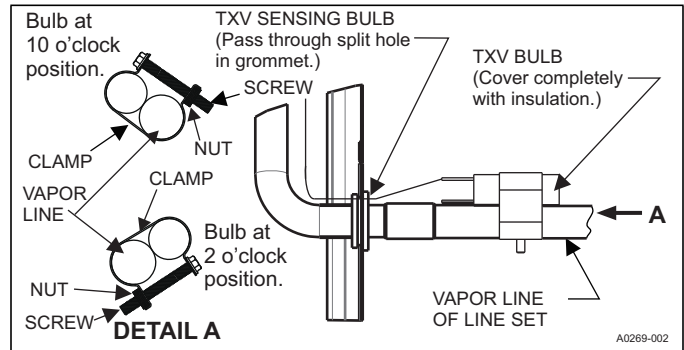

FIGURE 7: Proper Bulb Location

SECTION V: EVACUATION

It will be necessary to evacuate the system to 500 microns or less. If a leak is suspected, leak test with dry nitrogen to locate the leak. Repair the leak and test again.

To verify that the system has no leaks, simply close the valve to the vacuum pump suction to isolate the pump and hold the system under vacuum. Watch the micron gauge for a few minutes. If the micron gauge indicates a steady and continuous rise, it's an indication of a leak. If the gauge shows a rise, then levels off after a few minutes and remains fairly constant, it's an indication that the system is leak free but still contains moisture and may require further evacuation if the reading is above 500 microns.

SECTION VI: SYSTEM CHARGE

⚠ CAUTION

Refrigerant charging should only be carried out by a licensed qualified air conditioning contractor.

To ensure that your unit performs at the published levels, it is important that the indoor airflow is determined and refrigerant charge added accordingly.

MEASURE INDOOR AIR FLOW

To determine rated air flow for a specific match, consult the technical literature at www.upgnet.com. When attempting to match this air flow, select the lowest possible speed tap, measure the actual flow, and adjust as necessary.

To measure actual air flow, it is not an acceptable method to just check the jumper pin setting tables and is to assume 0.5" water column total external static pressure.

To determine indoor air flow, first measure the static pressure with a manometer between the filter and blower. On a single-piece air handler, take a second reading after the coil. On a furnace or modular air handler, take the second reading after the heat exchanger, but before the indoor coil. Add the negative return static to the positive supply static to determine the system total static pressure. Treat the negative return static as a positive pressure (even though it is a negative reading). If there is static pressure on the blower (i.e. -.10) return, add it to a supply static (.40) which equals a (.50) total system static pressure. Compare this value to the indoor blower performance charts ensuring air flow is between 35° -45° c CFM per ton of cooling.

CHARGING THE UNIT

⚠ CAUTION

Always charge in liquid form. Take care not to slug the compressor.

The factory charge in the outdoor unit includes enough charge for the unit, 15 ft. (4.6 m) of refrigerant piping, and the smallest indoor coil/air handler match-up. Some indoor coil/air handler matches may require additional charge.

⚠ CAUTION

Compressor damage will occur if system is improperly charged. On new system installations, charge system per tabular data sheet for the matched coil and follow guidelines in this instruction.

See Tabular Data Sheet provided in unit Customer Booklet for charge requirements. The "TOTAL SYSTEM CHARGE" must be permanently marked on the unit data plate.

⚠ CAUTION

Do not leave the system open to the atmosphere. Unit damage could occur due to moisture being absorbed by the POE oil in the system. This type of oil is highly susceptible to moisture absorption.

TOTAL SYSTEM CHARGE DETERMINED

1. Determine outdoor unit factory charge from Tabular Data Sheet.
2. Determine indoor coil adjustment (if any) from Tabular Data Sheet.
3. Calculate the additional charge for refrigerant piping using the Tabular Data Sheet if line length is greater than 15 feet (4.6 m).
4. Total system charge = item 1 + item 2 + item 3.
5. Check the unit against the pressure value listed on the cooling chart on the unit or the appropriate heat charging chart on the following pages of this Installation Manual. Make any adjustment necessary.
6. Add or subtract refrigerant to obtain the pressure listed on charging chart. Make sure to adjust the total system charge by the amount added or removed to obtain charging chart pressures. Permanently mark the unit data plate with the total amount of refrigerant in the system.

⚠ WARNING

DO NOT attempt to pump "Total System Charge" into outdoor unit for maintenance, service, etc. This may cause damage to the compressor and/or other components. Recover and weigh "System Charge" into an appropriate recovery cylinder for any instances requiring evacuation.

⚠ CAUTION

IT IS UNLAWFUL TO KNOWINGLY VENT, RELEASE OR DISCHARGE REFRIGERANT INTO THE OPEN AIR DURING REPAIR, SERVICE, MAINTENANCE OR THE FINAL DISPOSAL OF THIS UNIT.

CHARGING WITH GAUGES

⚠ CAUTION

Refrigerant charging should only be carried out by a qualified air conditioning contractor.

All units include a cooling charging chart for cooling. The heating charging charts in Table 3 through Table 10 in this document use the chart corresponding to the installed indoor coil. It can also be obtained at www.upgnet.com under the Service Application Data section.

⚠ CAUTION

Compressor damage will occur if system is improperly charged. On new system installations, charge system per tabular data sheet for the matched coil and follow guidelines in this instruction.

Before using gauges, confirm that your gauges are accurate by comparing the gauges against a calibrated pressure gauge that has been calibrated against a national standard. If a calibrated pressure gauge is not available, place a R-410A virgin refrigerant container in a conditioned space long enough to come to temperature equilibrium with the surroundings. Then measure the temperature of the air and the pressure of the refrigerant and compare it to the following table:

TABLE 2: R-410A Saturation Properties

Temp (°F)	Pressure (Psig)	Temp (°F)	Pressure (Psig)	Temp (°F)	Pressure (Psig)
40	119	75	218	110	365
45	130	80	236	115	391
50	143	85	255	120	418
55	156	90	274	125	447
60	170	95	295	130	477
65	185	100	317	–	–
70	201	105	341	–	–

Before measuring the pressures, use the method above to check the air flow and then consult the table and match the liquid pressure to that air flow.

Reference the heat charging charts in Table 3 through Table 10

TABLE 3: YHE18 Heat Charging Charts

YHE/TH4/RHP14L18		CF/CM/CU18, AP18, AE18, AVC18																	
CFM	Ambient Temperature (°F)	60			47			40			30			17			10		
	Indoor Temperature (°F)	60	70	80	60	70	80	60	70	80	60	70	80	60	70	80	60	70	80
450	Liquid Pressure (PSIG)	381	427	472	351	394	436	336	384	432	318	363	409	274	324	375	276	318	361
600	Liquid Pressure (PSIG)	345	389	434	319	355	404	308	354	400	294	338	382	263	308	354	259	300	342
750	Liquid Pressure (PSIG)	309	352	395	286	329	372	281	325	369	270	313	356	251	292	333	243	283	322
-	Suction Pressure (PSIG)	136			111			97			80			59			52		
YHE/TH4/RHP14L18		CF/CM/CU24, AP24, AE24, AVC24																	
CFM	Ambient Temperature (°F)	60			47			40			30			17			10		
	Indoor Temperature (°F)	60	70	80	60	70	80	60	70	80	60	70	80	60	70	80	60	70	80
450	Liquid Pressure (PSIG)	387	434	480	357	400	444	342	390	439	323	370	416	278	330	381	280	324	367
600	Liquid Pressure (PSIG)	351	396	441	324	361	411	314	360	407	299	344	389	267	313	360	264	306	347
750	Liquid Pressure (PSIG)	315	358	402	291	335	378	286	330	375	275	318	362	256	297	339	247	288	328
-	Suction Pressure (PSIG)	145			119			104			85			63			55		
YHE/TH4/RHP14L18		FC/MC/PC18, AHE18, AHV18																	
CFM	Ambient Temperature (°F)	60			47			40			30			17			10		
	Indoor Temperature (°F)	60	70	80	60	70	80	60	70	80	60	70	80	60	70	80	60	70	80
450	Liquid Pressure (PSIG)	409	458	507	377	423	468	361	412	463	341	390	439	294	348	402	296	341	387
600	Liquid Pressure (PSIG)	370	418	466	342	381	434	331	380	429	316	363	410	282	331	380	278	322	367
750	Liquid Pressure (PSIG)	332	378	424	307	353	399	301	349	396	290	336	382	270	314	357	261	303	346
-	Suction Pressure (PSIG)	147			120			104			86			63			56		
YHE/TH4/RHP14L18		FC/MC/PC24, FC/MC/PC30																	
CFM	Ambient Temperature (°F)	60			47			40			30			17			10		
	Indoor Temperature (°F)	60	70	80	60	70	80	60	70	80	60	70	80	60	70	80	60	70	80
450	Liquid Pressure (PSIG)	382	428	474	352	395	437	337	385	433	319	364	410	275	325	376	276	319	362
600	Liquid Pressure (PSIG)	346	391	435	320	356	405	309	355	401	295	339	383	263	309	355	260	301	343
750	Liquid Pressure (PSIG)	310	353	396	287	330	373	282	326	370	271	314	357	252	293	334	244	284	323
-	Suction Pressure (PSIG)	147			120			104			86			63			56		

TABLE 4: YHE24 Heat Charging Charts

YHE/TH4/RHP14L24		CF/CM/CU24, AP24, AE24, AVC24																	
CFM	Ambient Temperature (°F)	60			47			40			30			17			10		
	Indoor Temperature (°F)	60	70	80	60	70	80	60	70	80	60	70	80	60	70	80	60	70	80
600	Liquid Pressure (PSIG)	399	449	498	368	418	467	353	401	449	332	380	427	298	344	389	286	331	375
800	Liquid Pressure (PSIG)	359	407	454	335	366	431	322	358	415	306	352	397	280	323	365	269	312	354
1000	Liquid Pressure (PSIG)	319	365	410	301	348	394	292	337	382	280	324	367	262	302	342	253	293	333
-	Suction Pressure (PSIG)	136			109			96			80			60			52		
YHE/TH4/RHP14L24		CF/CM/CU30, AP30, AE30, AVC30																	
CFM	Ambient Temperature (°F)	60			47			40			30			17			10		
	Indoor Temperature (°F)	60	70	80	60	70	80	60	70	80	60	70	80	60	70	80	60	70	80
600	Liquid Pressure (PSIG)	378	425	472	349	396	443	335	380	426	315	360	405	283	326	369	271	313	356
800	Liquid Pressure (PSIG)	340	385	430	318	347	409	305	339	393	290	333	376	265	306	346	255	295	336
1000	Liquid Pressure (PSIG)	302	346	389	285	329	374	277	320	362	265	307	348	248	286	324	240	278	316
-	Suction Pressure (PSIG)	136			111			97			80			59			52		

Table 4 Continued on Next Page.

TABLE 4: YHE24 Heat Charging Charts (Continued)

YHE/TH4/RHP14L24			FC/MC/PC24, FC/MC/PC30																	
CFM	Ambient Temperature (°F)	60			47			40			30			17			10			
	Indoor Temperature (°F)	60	70	80	60	70	80	60	70	80	60	70	80	60	70	80	60	70	80	
600	Liquid Pressure (PSIG)	390	439	487	360	408	457	345	392	439	325	371	418	291	336	380	280	323	367	
800	Liquid Pressure (PSIG)	351	398	444	328	358	422	315	350	406	299	344	388	274	315	357	263	305	346	
1000	Liquid Pressure (PSIG)	312	357	401	294	340	385	286	330	374	274	316	359	256	295	335	247	287	326	
-	Suction Pressure (PSIG)	136			111			97			80			59			52			

YHE/TH4/RHP14L24			FC/MC/PC32, FC/MC/PC35, AHE/AHV24, AHR/AHV/AHE30																	
CFM	Ambient Temperature (°F)	60			47			40			30			17			10			
	Indoor Temperature (°F)	60	70	80	60	70	80	60	70	80	60	70	80	60	70	80	60	70	80	
600	Liquid Pressure (PSIG)	361	406	450	333	378	422	319	363	406	300	343	386	270	311	352	259	299	339	
800	Liquid Pressure (PSIG)	325	368	411	303	331	390	291	324	375	277	318	359	253	292	330	243	282	320	
1000	Liquid Pressure (PSIG)	288	330	371	272	314	356	264	305	345	253	293	332	237	273	309	229	265	301	
-	Suction Pressure (PSIG)	136			111			97			80			59			52			

TABLE 5: YHE30 Heat Charging Charts

YHE/TH4/THE/RHP14L30			AE30																	
CFM	Ambient Temperature (°F)	60			47			40			30			17			10			
	Indoor Temperature (°F)	60	70	80	60	70	80	60	70	80	60	70	80	60	70	80	60	70	80	
800	Liquid Pressure (PSIG)	379	428	477	355	404	453	317	380	442	326	373	420	302	343	384	295	336	378	
1000	Liquid Pressure (PSIG)	349	397	445	329	365	425	306	360	414	304	350	396	285	324	364	278	318	358	
1200	Liquid Pressure (PSIG)	320	366	413	303	350	396	294	340	385	282	327	373	268	306	345	262	301	339	
-	Suction Pressure (PSIG)	130			106			94			78			59			52			

YHE/TH4/THE/RHP14L30			CF/CM/CU36, CF/CM/CU42, AP/AVC30, AP/AE/AVC36, FC/MC/PC32, FC/MC/PC35, AHE30, AHV30																	
CFM	Ambient Temperature (°F)	60			47			40			30			17			10			
	Indoor Temperature (°F)	60	70	80	60	70	80	60	70	80	60	70	80	60	70	80	60	70	80	
800	Liquid Pressure (PSIG)	366	413	460	343	390	437	306	366	426	315	360	405	291	331	370	284	324	364	
1000	Liquid Pressure (PSIG)	337	383	429	317	352	410	295	347	399	293	338	382	275	313	351	268	307	346	
1200	Liquid Pressure (PSIG)	308	353	398	292	337	382	284	328	372	272	316	360	258	295	332	252	290	327	
-	Suction Pressure (PSIG)	127			104			92			76			57			51			

YHE/TH4/THE/RHP14L30			FC/MC/PC37, FC/MC/PC43, AHR36, AHE36, AHV36																	
CFM	Ambient Temperature (°F)	60			47			40			30			17			10			
	Indoor Temperature (°F)	60	70	80	60	70	80	60	70	80	60	70	80	60	70	80	60	70	80	
800	Liquid Pressure (PSIG)	341	385	429	319	363	407	285	341	397	293	335	377	271	308	345	265	302	339	
1000	Liquid Pressure (PSIG)	314	357	400	296	328	382	275	323	372	273	315	356	256	292	327	250	286	322	
1200	Liquid Pressure (PSIG)	287	329	371	272	314	356	264	305	346	253	294	335	241	275	310	235	270	305	
-	Suction Pressure (PSIG)	127			104			92			76			57			51			

TABLE 6: YHE35 Heat Charging Charts

YHE/TH4/RHP14L35			CF/CM/CU36, AE36, AVC36																	
CFM	Ambient Temperature (°F)	60			47			40			30			17			10			
	Indoor Temperature (°F)	60	70	80	60	70	80	60	70	80	60	70	80	60	70	80	60	70	80	
1000	Liquid Pressure (PSIG)	353	401	449	331	378	424	319	368	417	301	349	397	280	325	370	271	316	362	
1200	Liquid Pressure (PSIG)	331	376	421	311	344	403	302	338	398	287	332	377	268	312	356	258	303	348	
1400	Liquid Pressure (PSIG)	309	351	393	292	336	381	285	332	379	272	315	357	255	299	342	246	290	335	
-	Suction Pressure (PSIG)	136			109			96			80			60			52			

Table 6 Continued on next page.

TABLE 6: YHE35 Heat Charging Charts (Continued)

YHE/TH4/RHP14L35		CF/CM/CU42, AE42, AVC42																	
CFM	Ambient Temperature (°F)	60			47			40			30			17			10		
	Indoor Temperature (°F)	60	70	80	60	70	80	60	70	80	60	70	80	60	70	80	60	70	80
1000	Liquid Pressure (PSIG)	342	389	436	321	367	412	310	357	404	293	339	385	272	316	359	263	307	351
1200	Liquid Pressure (PSIG)	321	365	409	302	334	391	293	328	386	278	322	366	260	303	346	251	294	338
1400	Liquid Pressure (PSIG)	300	341	382	283	327	370	277	322	368	264	306	347	248	290	332	238	282	325
-	Suction Pressure (PSIG)	136			109			96			80			60			52		
YHE/TH4/RHP14L35		CF/CM/CU48																	
CFM	Ambient Temperature (°F)	60			47			40			30			17			10		
	Indoor Temperature (°F)	60	70	80	60	70	80	60	70	80	60	70	80	60	70	80	60	70	80
1000	Liquid Pressure (PSIG)	337	383	429	316	361	406	305	352	398	288	334	379	268	311	354	259	302	346
1200	Liquid Pressure (PSIG)	317	360	403	298	329	385	289	323	380	274	317	361	256	298	340	247	290	333
1400	Liquid Pressure (PSIG)	296	336	376	279	322	365	273	317	362	260	301	342	244	286	327	235	278	321
-	Suction Pressure (PSIG)	136			109			96			80			60			52		
YHE/TH4/RHP14L35		FC/MC/PC37, FC/MC/PC43, AHE/AHV36																	
CFM	Ambient Temperature (°F)	60			47			40			30			17			10		
	Indoor Temperature (°F)	60	70	80	60	70	80	60	70	80	60	70	80	60	70	80	60	70	80
1000	Liquid Pressure (PSIG)	332	377	423	311	356	400	301	346	392	284	329	374	264	306	349	255	298	341
1200	Liquid Pressure (PSIG)	312	354	397	293	324	379	285	318	375	270	313	355	252	294	335	243	286	328
1400	Liquid Pressure (PSIG)	291	331	371	275	317	359	269	313	357	256	296	337	241	281	322	231	273	316
-	Suction Pressure (PSIG)	136			109			96			80			60			52		
YHE/TH4/RHP14L35		FC/MC/PC48, AHE/AHV42																	
CFM	Ambient Temperature (°F)	60			47			40			30			17			10		
	Indoor Temperature (°F)	60	70	80	60	70	80	60	70	80	60	70	80	60	70	80	60	70	80
1000	Liquid Pressure (PSIG)	321	365	408	301	344	386	290	335	379	274	318	361	255	296	337	246	288	329
1200	Liquid Pressure (PSIG)	301	342	383	283	313	367	275	308	362	261	302	343	244	284	324	235	276	317
1400	Liquid Pressure (PSIG)	282	320	358	265	306	347	259	302	345	248	286	325	232	272	311	223	264	305
-	Suction Pressure (PSIG)	136			109			96			80			60			52		

TABLE 7: YHE36 Heat Charging Charts

YHE/THE/TH4/RHP14L36		CF/CM/CU48, AP37, AE42, AE48																	
CFM	Ambient Temperature (°F)	60			47			40			30			17			10		
	Indoor Temperature (°F)	60	70	80	60	70	80	60	70	80	60	70	80	60	70	80	60	70	80
1000	Liquid Pressure (PSIG)	391	437	483	361	410	459	345	387	429	320	365	410	292	330	369	263	303	342
1200	Liquid Pressure (PSIG)	366	411	457	339	372	436	326	362	412	304	349	394	282	320	357	258	294	330
1400	Liquid Pressure (PSIG)	341	385	430	318	365	413	307	351	396	287	332	377	272	309	345	253	285	317
-	Suction Pressure (PSIG)	136			109			96			80			60			52		
YHE/THE/TH4/RHP14L36		FC/MC/PC48, AHE42, AHR42, AHV42																	
CFM	Ambient Temperature (°F)	60			47			40			30			17			10		
	Indoor Temperature (°F)	60	70	80	60	70	80	60	70	80	60	70	80	60	70	80	60	70	80
1000	Liquid Pressure (PSIG)	365	408	451	337	382	428	322	361	400	299	340	382	272	308	344	245	282	319
1200	Liquid Pressure (PSIG)	342	384	426	316	347	406	304	338	385	283	325	367	263	298	333	240	274	308
1400	Liquid Pressure (PSIG)	318	359	401	296	341	385	286	328	369	268	310	352	254	288	322	236	266	296
-	Suction Pressure (PSIG)	136			109			96			80			60			52		

TABLE 8: YHE42 Heat Charging Charts

YHE/THE/TH4/RHP14L42		CF/CM/CU48, AE42, AE48, AVC42, AVC48																	
CFM	Ambient Temperature (°F)	60			47			40			30			17			10		
	Indoor Temperature (°F)	60	70	80	60	70	80	60	70	80	60	70	80	60	70	80	60	70	80
1100	Liquid Pressure (PSIG)	387	418	449	331	378	424	319	368	417	301	349	397	280	325	370	271	316	362
1300	Liquid Pressure (PSIG)	362	391	421	311	370	403	302	350	398	287	332	377	268	312	356	258	303	348
1500	Liquid Pressure (PSIG)	337	365	393	292	336	381	285	332	379	272	315	357	255	299	342	246	290	335
-	Suction Pressure (PSIG)	126			103			91			74			51			45		
YHE/THE/TH4/RHP14L42		CF/CM/CU60, AE60C, AVC60C																	
CFM	Ambient Temperature (°F)	60			47			40			30			17			10		
	Indoor Temperature (°F)	60	70	80	60	70	80	60	70	80	60	70	80	60	70	80	60	70	80
1100	Liquid Pressure (PSIG)	371	401	430	317	362	407	306	353	400	289	335	381	269	312	355	260	303	347
1300	Liquid Pressure (PSIG)	347	376	404	299	355	386	290	336	382	275	318	362	257	299	342	248	291	334
1500	Liquid Pressure (PSIG)	323	350	377	280	323	366	274	318	363	261	302	343	245	286	328	236	279	322
-	Suction Pressure (PSIG)	122			100			88			71			49			43		
YHE/THE/TH4/RHP14L42		FC/MC/PC48, AHE42, AHV42																	
CFM	Ambient Temperature (°F)	60			47			40			30			17			10		
	Indoor Temperature (°F)	60	70	80	60	70	80	60	70	80	60	70	80	60	70	80	60	70	80
1100	Liquid Pressure (PSIG)	368	397	427	315	359	404	304	350	396	287	332	377	267	309	352	258	301	344
1300	Liquid Pressure (PSIG)	344	372	401	296	352	383	287	333	378	273	316	359	255	297	339	246	289	331
1500	Liquid Pressure (PSIG)	321	347	374	277	320	363	271	316	360	259	299	340	243	284	325	234	276	319
-	Suction Pressure (PSIG)	123			101			89			72			50			44		
YHE/THE/TH4/RHP14L42		FC/MC/PC60, AHE48, AHV48																	
CFM	Ambient Temperature (°F)	60			47			40			30			17			10		
	Indoor Temperature (°F)	60	70	80	60	70	80	60	70	80	60	70	80	60	70	80	60	70	80
1100	Liquid Pressure (PSIG)	357	386	415	306	349	392	295	340	385	279	323	367	259	301	342	250	292	334
1300	Liquid Pressure (PSIG)	334	362	389	288	342	372	279	323	368	265	307	348	248	288	329	239	280	322
1500	Liquid Pressure (PSIG)	311	338	364	270	311	352	264	307	350	252	291	330	236	276	316	227	268	310
-	Suction Pressure (PSIG)	124			102			90			73			50			44		

TABLE 9: YHE48 Heat Charging Charts

YHE/THE/TH4/RHP14L48		CF/CM/CU48, AE48, AVC48																	
CFM	Ambient Temperature (°F)	60			47			40			30			17			10		
	Indoor Temperature (°F)	60	70	80	60	70	80	60	70	80	60	70	80	60	70	80	60	70	80
1400	Liquid Pressure (PSIG)	385	441	496	357	411	465	336	394	453	319	368	417	264	332	400	284	323	362
1600	Liquid Pressure (PSIG)	367	419	472	341	392	446	325	380	435	306	354	401	271	330	389	274	312	350
1800	Liquid Pressure (PSIG)	349	398	448	325	375	426	313	366	418	293	339	385	278	328	379	264	301	338
-	Suction Pressure (PSIG)	128			105			93			76			57			50		
YHE/THE/TH4/RHP14L48		CF/CM/CU60																	
CFM	Ambient Temperature (°F)	60			47			40			30			17			10		
	Indoor Temperature (°F)	60	70	80	60	70	80	60	70	80	60	70	80	60	70	80	60	70	80
1400	Liquid Pressure (PSIG)	336	384	433	312	359	406	293	344	395	279	321	364	230	290	349	248	282	316
1600	Liquid Pressure (PSIG)	320	366	412	298	342	389	283	332	380	267	309	350	236	288	340	239	272	305
1800	Liquid Pressure (PSIG)	304	348	391	283	328	372	273	319	365	256	296	336	242	286	330	230	263	295
-	Suction Pressure (PSIG)	128			105			93			76			57			50		

Table 9 Continued on Next Page.

TABLE 9: YHE48 Heat Charging Charts (Continued)

YHE/THE/TH4/RHP14L48		AE60C, AVC60C, FC/MC/PC48																	
CFM	Ambient Temperature (°F)	60			47			40			30			17			10		
	Indoor Temperature (°F)	60	70	80	60	70	80	60	70	80	60	70	80	60	70	80	60	70	80
1400	Liquid Pressure (PSIG)	354	405	455	328	378	427	309	362	416	293	338	383	243	305	367	261	296	332
1600	Liquid Pressure (PSIG)	337	385	433	313	360	409	298	349	400	281	325	368	249	303	358	251	286	321
1800	Liquid Pressure (PSIG)	320	366	412	298	345	391	288	336	384	269	312	354	255	302	348	242	276	310
-	Suction Pressure (PSIG)	128			105			93			76			57			50		

YHE/THE/TH4/RHP14L48		FC/MC/PC60, AHE48, AHV48																	
CFM	Ambient Temperature (°F)	60			47			40			30			17			10		
	Indoor Temperature (°F)	60	70	80	60	70	80	60	70	80	60	70	80	60	70	80	60	70	80
1400	Liquid Pressure (PSIG)	349	399	449	324	372	421	305	357	410	289	333	378	239	301	362	257	292	328
1600	Liquid Pressure (PSIG)	332	380	427	309	355	404	294	344	394	277	320	363	245	299	353	248	282	317
1800	Liquid Pressure (PSIG)	316	361	406	294	340	386	284	331	379	266	307	349	252	297	343	239	272	306
-	Suction Pressure (PSIG)	128			105			93			76			57			50		

YHE/THE/TH4/RHP14L48		FC/MC62, AHE60																	
CFM	Ambient Temperature (°F)	60			47			40			30			17			10		
	Indoor Temperature (°F)	60	70	80	60	70	80	60	70	80	60	70	80	60	70	80	60	70	80
1400	Liquid Pressure (PSIG)	328	375	422	305	350	396	287	336	386	272	314	355	225	283	341	242	275	308
1600	Liquid Pressure (PSIG)	313	357	402	291	334	380	277	324	371	261	301	342	231	281	332	233	266	298
1800	Liquid Pressure (PSIG)	297	339	382	277	320	363	267	311	356	250	289	328	237	280	323	225	256	288
-	Suction Pressure (PSIG)	128			105			93			76			57			50		

TABLE 10: YHE60 Heat Charging Charts

YHE/THE/TH4/RHP14L60		CF/CM/CU64, AE60D, AVC60D																	
CFM	Ambient Temperature (°F)	60			47			40			30			17			10		
	Indoor Temperature (°F)	60	70	80	60	70	80	60	70	80	60	70	80	60	70	80	60	70	80
1615	Liquid Pressure (PSIG)	340	385	430	315	345	404	302	333	392	288	331	373	270	311	351	260	300	341
1865	Liquid Pressure (PSIG)	315	358	402	294	324	380	284	326	371	271	312	353	258	299	340	248	288	328
2115	Liquid Pressure (PSIG)	290	332	374	273	302	357	265	295	350	254	293	333	245	287	329	237	276	316
-	Suction Pressure (PSIG)	128			103			90			71			57			50		

YHE/THE/TH4/RHP14L60		FC/MC62, AHE60																	
CFM	Ambient Temperature (°F)	60			47			40			30			17			10		
	Indoor Temperature (°F)	60	70	80	60	70	80	60	70	80	60	70	80	60	70	80	60	70	80
1615	Liquid Pressure (PSIG)	380	430	480	352	385	452	338	372	438	322	369	417	302	347	392	290	335	381
1865	Liquid Pressure (PSIG)	352	401	449	329	362	425	317	364	414	303	349	394	288	334	380	277	322	367
2115	Liquid Pressure (PSIG)	324	371	418	305	337	398	296	330	391	284	328	372	274	321	368	264	308	353
-	Suction Pressure (PSIG)	128			103			90			71			57			50		

YHE/THE/TH4/RHP14L60		FC/MC64																	
CFM	Ambient Temperature (°F)	60			47			40			30			17			10		
	Indoor Temperature (°F)	60	70	80	60	70	80	60	70	80	60	70	80	60	70	80	60	70	80
1615	Liquid Pressure (PSIG)	349	395	442	324	355	415	311	342	403	296	340	383	278	319	361	267	309	350
1865	Liquid Pressure (PSIG)	324	368	413	302	333	391	292	335	381	279	321	363	265	307	350	255	296	337
2115	Liquid Pressure (PSIG)	298	341	384	281	310	366	273	303	359	261	302	342	252	295	338	243	284	324
-	Suction Pressure (PSIG)	128			103			90			71			57			50		

SECTION VII: ELECTRICAL CONNECTIONS

GENERAL INFORMATION & GROUNDING

The control box cover is held in place with 3 screws (one screw in each lower corner and one screw at the top center post). The control box can swing open by removing the screw from the center of each side of the control box and allowing the control box to lower an inch or so into a pivotal position.

NOTICE

A flexible electrical whip must be installed in order to use the swing away function of the control box. Other type electrical whips require the wiring to be disconnected in order to swing the control box open.

The control box can then swing open from the left by rotating on the right side pivots for easy service of refrigeration components. If no wiring is in or routed through the control box, it can be removed from the unit by lifting slightly, tilting the top hinge out, and lifting the bottom hinge out. During the installation, it is recommended to route the low voltage wiring for the thermostat along the unit whip to help facilitate the swing away feature of the control box. Refer to Figure 8.

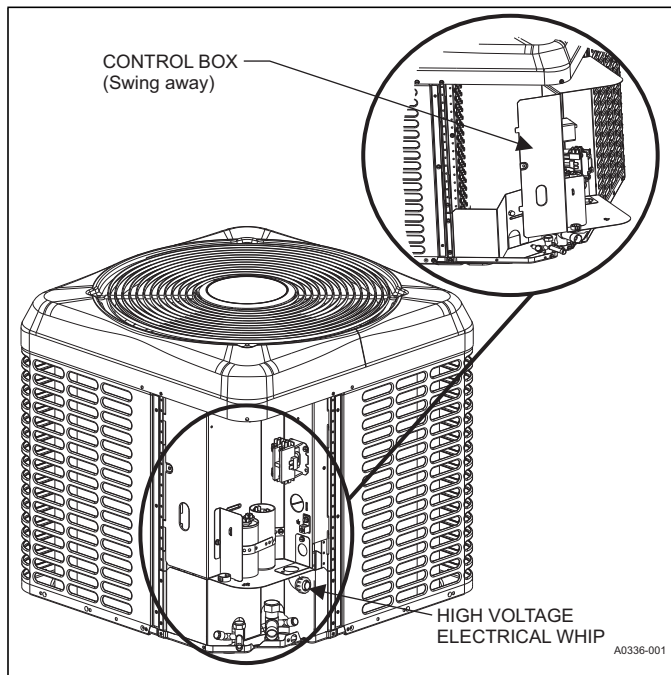

FIGURE 8: Outdoor Unit Swing Away Control Box

Check the electrical supply to be sure that it meets the values specified on the unit nameplate and wiring label.

Power wiring, control (low voltage) wiring, disconnect switches and over current protection must be supplied by the installer. Wire size should be sized per NEC requirements.

CAUTION

All field wiring must **USE COPPER CONDUCTORS ONLY** and be in accordance with *Local, National, Fire, Safety & Electrical Codes*. This unit must be grounded with a separate ground wire in accordance with the above codes.

The complete connection diagram and schematic wiring label is located on the inside surface of the unit service access panel.

FIELD CONNECTIONS POWER WIRING

1. Install the proper size weatherproof disconnect switch outdoors and within sight of the unit.
2. Remove the screws at the top and sides of the corner cover. Slide the control box cover down and remove from unit.
3. Run power wiring from the disconnect switch to the unit.
4. Route wires from disconnect through power wiring exit provided and into the unit control box as shown in Figures 9 & 10.
5. Install the proper size time-delay fuses or circuit breaker, and make the power supply connections.

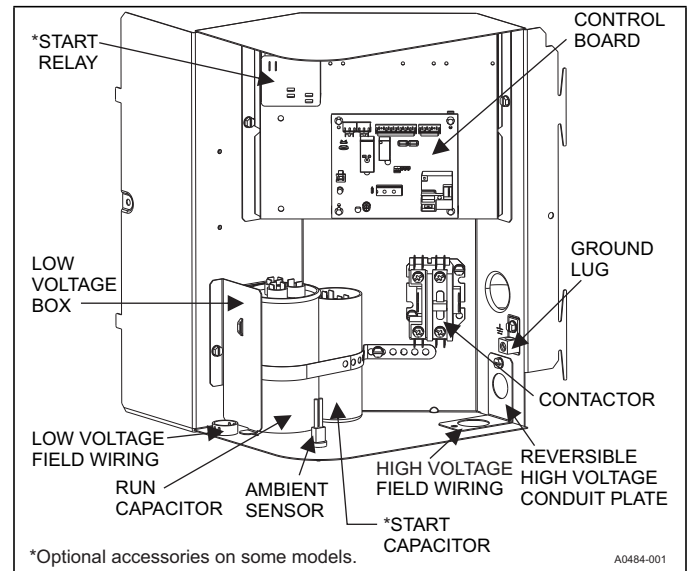

FIGURE 9: Outdoor Unit Control Box (208/230V Single Phase)

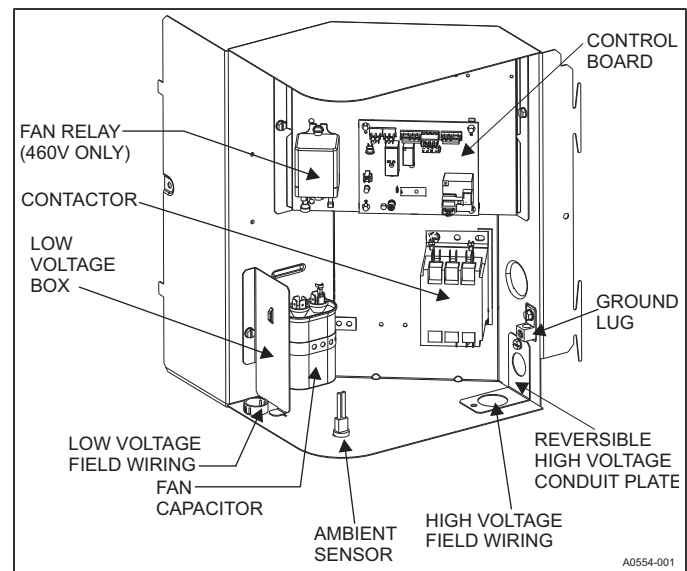

FIGURE 10: Outdoor Unit Control Box (208/230V & 460V 3-Phase)

FIELD CONNECTIONS CONTROL WIRING

1. Route low voltage wiring into bottom of control box as shown in Figure 9 or 10. Make low voltage wiring connections inside the low voltage box per Figure 11.
2. The complete connection diagram and schematic wiring label is located on the inside surface of the unit service access panel.
3. Replace the control box cover removed in Step 2 of the FIELD CONNECTINS POWER WIRING procedures.
4. All field wiring to be in accordance with national electrical codes (NEC) and/or local-city codes.

NOTICE

A Start Assist Kit is available and recommended for long line set applications or in areas of known low voltage problems. The kit may be required when a TXV is used (reference the Tabular Data Sheet to determine if applicable).

5. Mount the thermostat about 5 ft. above the floor, where it will be exposed to normal room air circulation. Do not place it on an outside wall or where it is exposed to the radiant effect from exposed glass or appliances, drafts from outside doors or supply air grilles.
6. Route the 24-volt control wiring (NEC Class 2) from the outdoor unit to the indoor unit and thermostat.

NOTICE

To eliminate erratic operation, seal the hole in the wall at the thermostat with permagum or equivalent to prevent air drafts affecting the operation of in the thermostat.

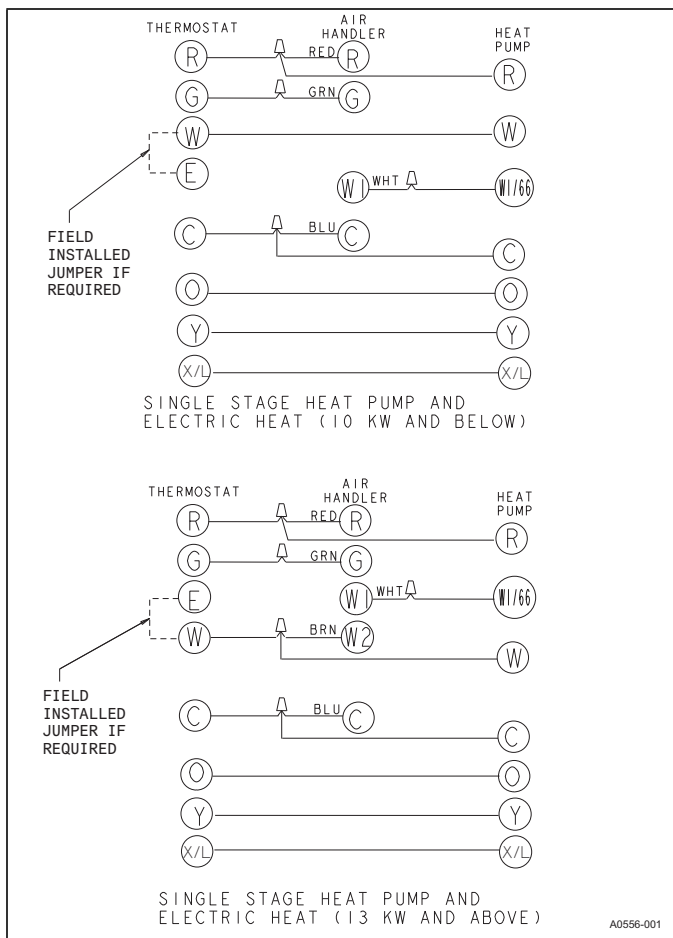

FIGURE 11: Typical Field Wiring (Air Handler / Electrical Heat) (Single and Three-Phase)

DEHUMIDIFICATION CONTROL (Typical)

The indoor unit Installation Manual instructions for the air handler or furnace describe the interface with the outdoor heat pump. A dehumidification control accessory 2HU16700124 may be used with variable speed air handlers or furnaces in high humidity areas. This control works with the variable speed indoor unit to provide cooling at a reduced air flow, lowering evaporator temperature and increasing latent capacity. The humidistat in this control opens the humidistat contacts as the humidity increases. Installation instructions are packaged with the accessory. Prior to the installation of the dehumidification control, the humidistat jumper must be set to 'YES' on the indoor variable speed air handler or furnace control board.

During cooling, if the relative humidity in the space is higher than the desired set point of the dehumidification control, the variable speed blower motor will operate at lower speed until the dehumidification control is satisfied. A 40-60% relative humidity level is recommended to achieve optimum comfort.

If a dehumidification control is installed, it is recommended that a minimum air flow of 325 cfm/ton be supplied at all times.

To see connection diagrams of all UPG equipment, the "Low Voltage System Wiring" document is available online at www.upgnet.com in the Product Catalog Section.

INDOOR CUBIC FEET PER MINUTE (CFM) SELECTION BOARD SETTINGS (Typical)

Refer to the indoor unit Installation Manual instructions for the air handler or furnace interface with the outdoor heat pump. Refer to the Outdoor Technical Guide for the recommended indoor air flow settings of each specific heat pump. For the system to operate correctly, ensure that the indoor CFM Selection control jumpers are properly set. Set the indoor cooling fan speed per the instructions for the air handler or furnace by selecting the correct COOL and ADJUST (or ADJ) taps. Verify the indoor airflow by using the LED display on the indoor CFM selection board.

SECTION VIII: SYSTEM START-UP

ENERGIZE CRANKCASE HEATER

In order to energize the crankcase heater, set the indoor cooling thermostat to the OFF position. Close the line power disconnect to the unit.

IMPORTANT

An attempt to start the compressor without at least 8 hours of crankcase heat will damage the compressor.

WITH POWER TO UNIT AND THERMOSTAT IN COOLING POSITION:

1. In the cooling cycle, discharge gas is pumped to the outdoor coil which is the condenser. The indoor coil is the evaporator.
2. If fan switch is in ON position, a circuit is made through the blower relay to provide continuous blower operation.
3. With fan switch in AUTO position, a circuit is made from thermostat cooling contact through blower relay to provide blower operation.
4. System will cycle with thermostat demand to provide cooling as needed.

SECTION IX: SYSTEM OPERATION

ANTI SHORT-CYCLE DELAY

The control includes a five-minute anti short-cycle delay (ASCD) timer to prevent the compressor from short-cycling after a power or thermostat signal interruption. The ASCD timer is applied when the control is first powered from the indoor unit thermostat and immediately following the completion of a compressor run cycle. The compressor and the outdoor fan will not operate during the five minutes that the timer is active.

The ASCD timer can be bypassed by shorting the TEST terminals for three seconds while the thermostat is calling for compressor operation (Y input signal energized).

LOW VOLTAGE DETECTION

The control monitors the transformer secondary (24 VAC) voltage and provides low voltage protection for the heat pump and its components. In particular, the control prevents contactor chatter during low voltage conditions. If the voltage drops below approximately 19 VAC, the control will continue to energize any relays that are already energized but will not energize any additional relays until the voltage level increases. If the voltage drops below approximately 16 VAC, the control will immediately de-energize the relay outputs and will not energize any relays until the voltage level increases.

TEST INPUT

The control includes a TEST input connector that can be used for various testing functions during installation and service. The TEST input connector is shown in Figure 13. The following table summarizes the behavior of the control when the two TEST pins are connected. More detailed descriptions of the various functions are included in other sections of this document.

TABLE 11: TEST Input Functionality with Y

Duration of connection (seconds)	Control behavior with thermostat signals present
< 2	No response
2-5	Bypass ASCD (Reduce timer to zero immediately). If Y1 is present and high-pressure switch is closed, contactors will be energized.
	Clear Pressure Switch Lockout and reset the 6 hour PS timer.
> 5	Initiate defrost cycle ignoring the COIL temp and record that defrost cycle was initiated by TEST short. Energize Wout and begin defrost cycle immediately upon expiration of timer.
Test Pin Short removed	Terminate defrost as normal.
Test pin Short not removed	Continue defrost cycle until TEST connection removed.

TABLE 12: TEST Input Functionality without Y

Duration of connection (seconds)	Control behavior with thermostat signals NOT present
< 2	No response
2-5	The control shall sequentially flash, on the STATUS LED, the series of stored error codes (up to the last 5 since active error codes were last cleared) starting with the most recent. If there are no error codes stored in memory, the STATUS LED shall flash 3 times (0.1 sec ON / 0.1 sec OFF).
> 5	The control shall immediately clear the stored error code array, reset the 6 hour PS timer and flash the STATUS LED 6 times (0.1 sec ON / 0.1 sec OFF) to indicate that the error memory has been cleared.

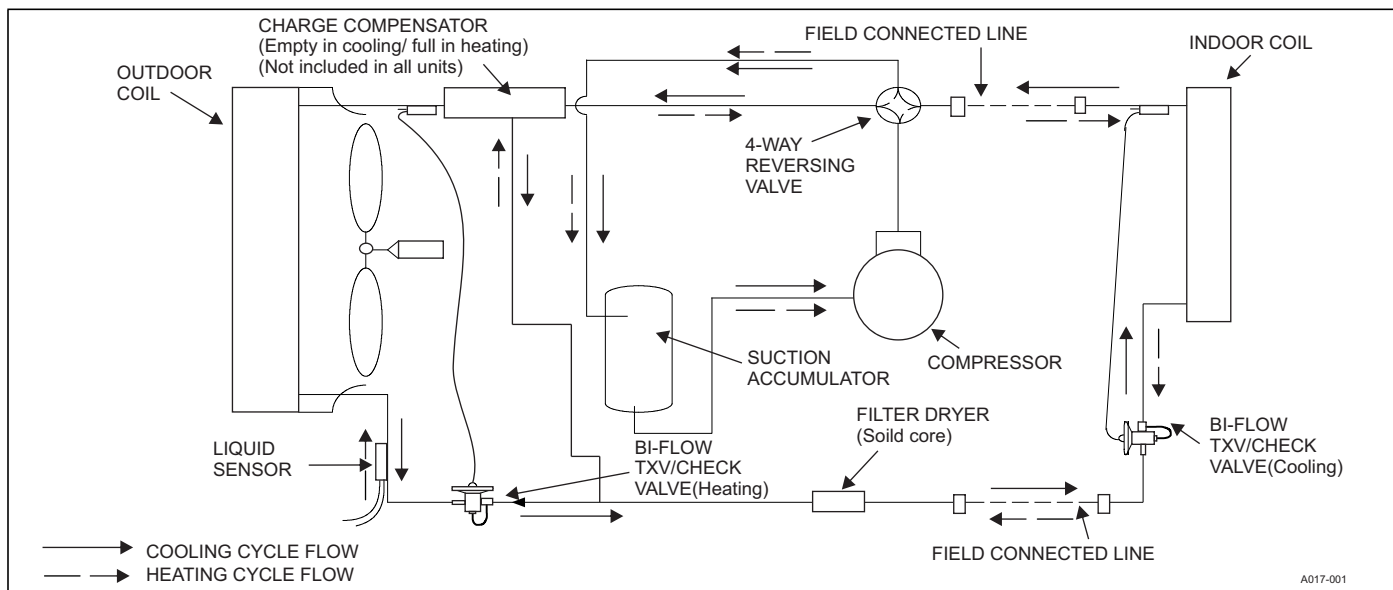

FIGURE 12: Heat Pump Flow Diagram

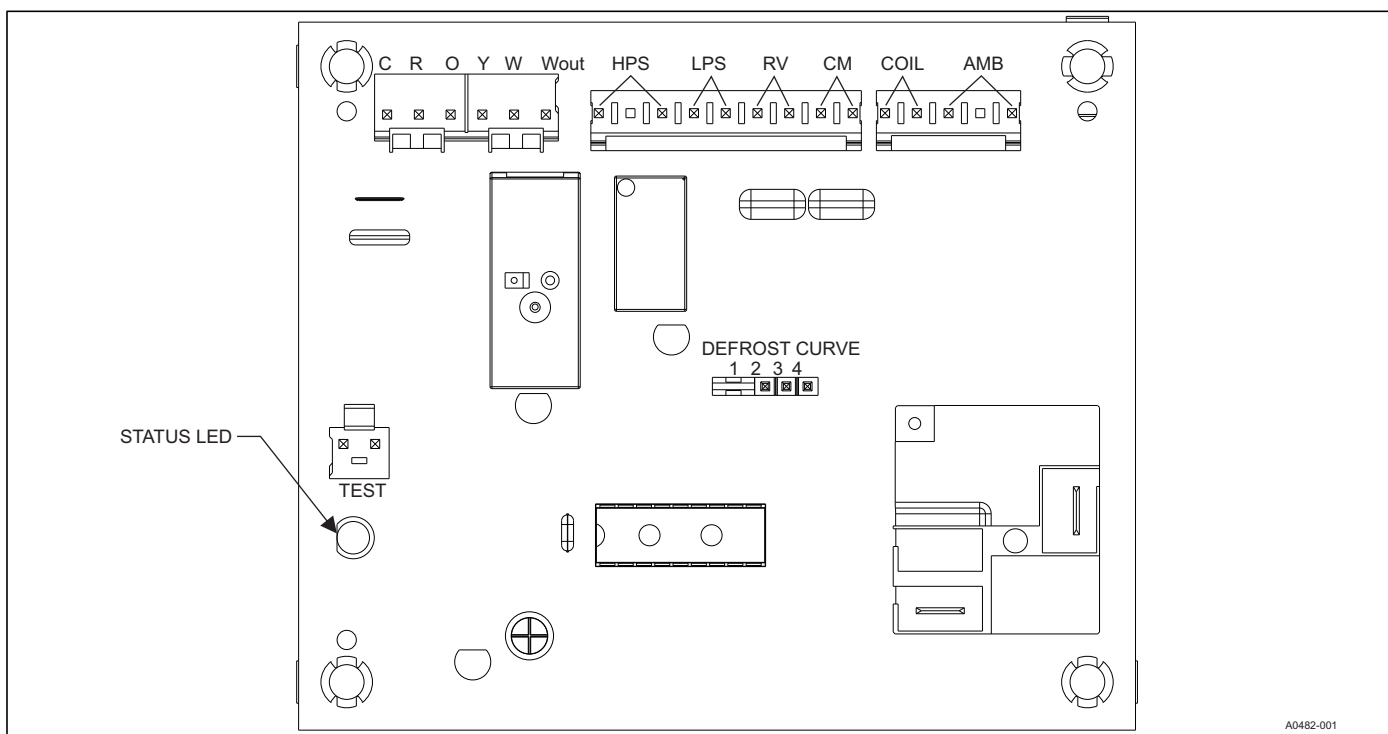

FIGURE 13: Demand Defrost Control Module

FAULT CODE DISPLAY

The control shall provide status codes using the LED. Status codes indicate the state of operation of the unit but do not represent a fault. The table below describes the LED displays during status codes. Status codes will not be displayed when a fault code is present.

TABLE 13: Status Code Display

No power to the control	No Faults active Nothing energized	OFF
Compressor Operation Active	No Faults active M energized	ON
Control normal operation – no call for compressor	No faults active Y not present	2s ON/2s OFF
Control normal operation – in ASCD period	No faults active, Y present, ASCD timer not expired	0.1 sec ON/0.1 sec OFF

The control shall provide fault codes using the Status LED. The table below describes the LED displays during fault codes. Unless otherwise specified, the control shall provide flashes that are a 1/3 second on and 1/3 second off for fault codes. The control shall only display a single fault code on the LED. The control shall display the fault code on the LED repeatedly with a 2 second off period between repetitions of the fault code. If multiple fault codes are present at the same time, the LED shall display only the most recent fault.

The table below shows a number that represents the number of flashes for the specified code. For instance, a flash code entry of 3 indicates that the control will energize the output for three 1/3 second on, 1/3 second off flashes, wait two seconds, then energize the output for three more 1/3 second on, 1/3 second off flashes and repeat.

TABLE 14: Status

Description	STATUS LED
High -pressure switch fault (not in lockout yet)	2 Flashes
System in high-pressure switch lockout (last mode of operation was normal compressor operation)	3 Flashes
System in high-pressure switch lockout (last mode of operation was defrost)	4 Flashes
System in low-pressure switch lockout (last mode of operation was normal compressor operation)	5 Flashes
Low Voltage (<19.2VAC) preventing further relay outputs for > 2 seconds	6 Flashes
Low Voltage (<16VAC) stopped current relay outputs for > 2 seconds	7 Flashes
Coil sensor failure (Open or Shorted)	8 Flashes
Outdoor ambient sensor failure (Open or Shorted)	9 Flashes
Control Failure	10 Flashes

Demand Defrost

The control maintains proper airflow through the outdoor coil during heating operation by melting frost and ice that may form on the coil. Frost may accumulate unevenly in different sections of the coil because of the arrangement of the refrigeration circuit within the coil. The control may initiate a defrost cycle even when the coil is not completely covered with frost. This is normal operation.

The control regulates the defrost operation of the heat pump based on accumulated compressor run time, outdoor coil temperature, and outdoor ambient temperature. The control will cause the heat pump unit to operate in the normal heating mode until it determines that a defrost cycle is needed.

All defrost timings are based on accumulated compressor run time.

Operation

The defrost mode is equivalent to the cooling mode except that the outdoor fan motor is de-energized. The control shall do the following to initiate a defrost cycle.

- De-energize the outdoor fan.
- Energize the reversing valve.
- Energize the auxiliary heat output through the Wout terminal.
- Begin the maximum defrost cycle length timer.

If the call for heating (Y) is removed from the control during the defrost cycle, it will terminate the defrost cycle and de-energize the compressor. The control will also stop the defrost cycle length timer but not reset it. When the control receives another call for heating, it will restart the defrost cycle and the timer at the point at which the call for heating was removed. This will happen only if the coil sensor temperature conditions allow defrost to occur.

Defrost Curves

The control uses a set of defrost curve parameters that are selected using the defrost curve selection jumper. The location of the defrost curve selection jumper is shown on the Tabular Data sheet for each heat pump model.

Defrost Curve Selection

The second page of the tabular data sheet indicates the proper jumper setting for the specific heat pump model.

The control only reads the jumper input when the Y and W thermostat inputs are de-energized. If a jumper position is changed while either of these inputs is energized, the control will not act upon the jumper changes until the thermostat calls are de-energized or power (24 VAC) to the control is cycled.

Defrost Cycle Initiation

The control will allow the heat pump to operate in the heating mode until the combination of outdoor ambient and outdoor coil temperatures indicate that a defrost cycle is necessary.

The control will initiate a defrost cycle when the coil temperature is below the initiate point for the measured ambient temperature (See Figure 14) continuously for 4-1/2 minutes. This delay eliminates unnecessary defrost cycles caused by refrigeration surges such as those that occur at the start of a heating cycle.

The control will initiate a defrost cycle every 6 hours (accumulated compressor run time) to recirculate refrigerant lubricants. This forced defrost timer will be reset and restarted following the completion or termination of a defrost cycle.

The control shall initiate a defrost cycle when the Defrost Inhibit Time Limit has elapsed if the previous defrost cycle was terminated based on the Maximum Defrost Cycle Time. This shall occur regardless of the liquid line (coil) temperature reading. The coil does not have to be cold for the unit to be forced into defrost. Once the defrost cycle begins the control shall follow the normal defrost cycle routine.

The control will also initiate a defrost cycle when the TEST terminals are shorted. This feature allows an installer or service technician to start a defrost cycle immediately as required. When the TEST terminals are shorted for more than 5 seconds with a Y input energized and the pressure switch input is closed, the ASCD will be bypassed, the reversing valve will be energized, the ODF will be de-energized and the compressor and the Wout terminal to auxiliary heat will be energized.

When the TEST inputs are used to force a defrost cycle, the control will ignore the state of the coil temperature and outdoor ambient temperature inputs. The coil does not have to be within a certain range for the heat pump to be forced into a defrost cycle. After the TEST input jumper is removed, the defrost mode will be terminated as normal. The defrost cycle length timer will not be started until the TEST input is removed. If the TEST terminals remain shorted, the control will keep the unit in defrost mode.

Defrost Inhibition

The control will not initiate a defrost cycle if the liquid line temperature is above 40° F unless the defrost cycle is forced using the TEST input, or the previous defrost exited on maximum time (12 minutes).

The control will also prevent a defrost cycle from being initiated too soon after the initiation of the previous defrost cycle. When power is applied to the control and after the completion or termination of each defrost cycle, the control will start a 40-minute timer. When this timer expires, the control will allow another defrost cycle when needed. The timer is based on accumulated compressor run time.

Defrost Termination

The control will terminate the defrost cycle immediately after the liquid line temperature reaches the terminate temperature or after 12 minutes of defrost operation. See Figure 14.

The control will do the following to terminate a defrost cycle:

- Energize the outdoor fan.
- De-energize the reversing valve.
- De-energize the auxiliary heat output through the Wout terminal.
- Reset and restart the 40-minute defrost inhibit timer.

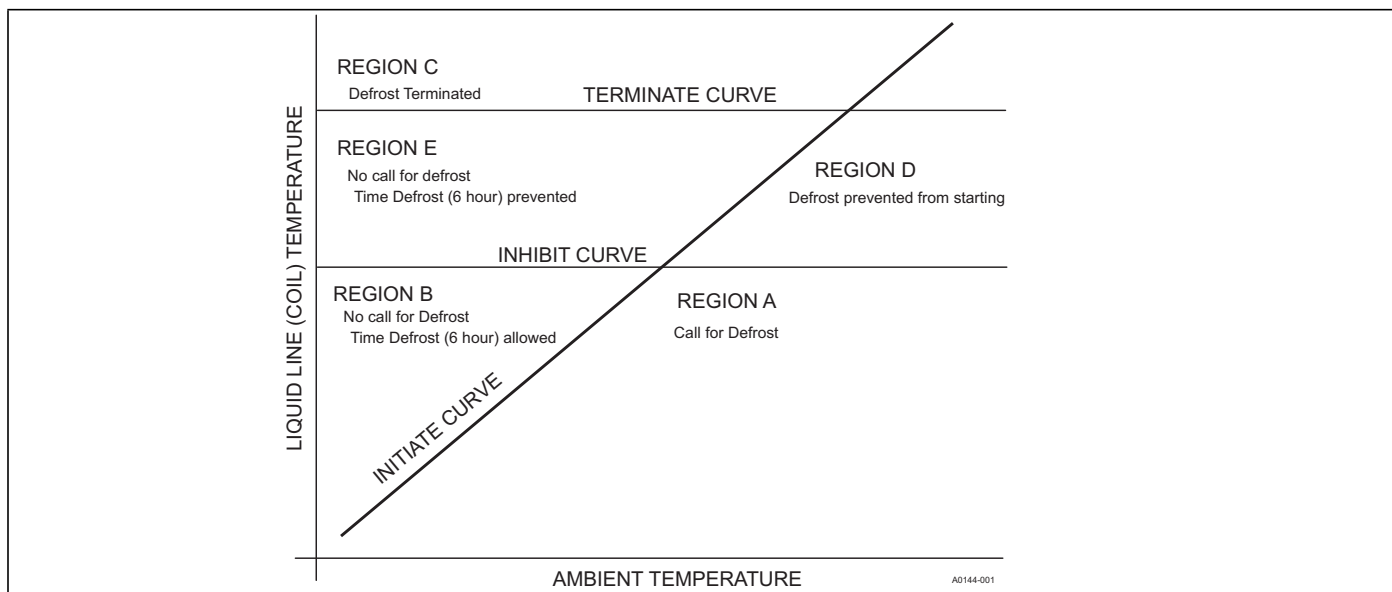

FIGURE 14: Defrost Operation Curves

COOLING OPERATION

During cooling operation, the control will receive thermostat signals at the Y and O input terminals. The control will energize the M compressor output terminal. This signal energizes the coil of the compressor contactor causing the compressor to run. The control also delivers power to the COND FAN terminals causing the outdoor fan to operate. The control energizes the REV VALVE terminal with 24VAC to switch the reversing valve.

HEATING OPERATION

During normal heating mode, the control will receive a thermostat signal at the Y input terminal. The control will energize the M compressor output terminal. This signal energizes the coil of the compressor contactor causing the compressor to run. The control also delivers power to the COND FAN terminals causing the outdoor fan to operate. The reversing valve is not energized in heating mode.

EMERGENCY HEAT

When the thermostat calls for emergency heat operation (W signal without a Y signal), the control will de-energize the compressor and energize the Wout terminal immediately.

PRESSURE SWITCH FAULT & LOCKOUT

The heat pump is equipped with a pressure switch and loss of charge switch that are connected to the control at the pressure switch terminals. If one of these switches input opens for more than 40 milliseconds, the control will de-energize the compressor. If the switch closes and a thermostat call for compressor operation is present, the control will apply the five-minute anti short-cycle delay timer and start the compressor when the timer expires.

When the compressor is started following a switch fault, the control will start a six-hour timer based on accumulated compressor run time. If the control senses another opening of the switch before the timer expires, it will cause a soft lockout condition. The second opening of the switch must be greater than 160 milliseconds for the lockout to occur. If the second opening is between 40 and 160 milliseconds, the control will de-energize the compressor but not cause a soft lockout condition. If the control does not sense a second switch opening before the six-hour timer expires, the timer and counter will be reset.

During the soft lockout mode, the control will de-energize the compressor and energize the LED output with the appropriate flash code.

The control will reset the soft lockout condition when any of the following occur after removal of the fault condition.

1. Power is cycled to the R or Y inputs of the control. This will cause the soft lockout condition to be reset when the thermostat is satisfied or when the thermostat is set to SYSTEM OFF and back to HEAT or COOL mode.
2. The TEST terminals are shorted for more than two seconds.

When the soft lockout condition is reset, the control will stop displaying the fault code and will respond to thermostat inputs normally.

SECTION X: INSTRUCTING THE OWNER

Assist owner with processing warranty cards and/or online registration. Review Owners Guide and provide a copy to the owner and guidance on proper operation and maintenance. Instruct the owner or the operator how to start, stop and adjust temperature setting.

When applicable, instruct the owner that the compressor is equipped with a crankcase heater to prevent the migration of refrigerant to the compressor during the OFF cycle. The heater is energized only when the unit is not running. If the main switch is disconnected for long periods of shut down, do not attempt to start the unit until 8 hours after the switch has been connected. This will allow sufficient time for all liquid refrigerant to be driven out of the compressor.

The installer should also instruct the owner on proper operation and maintenance of all other system components.

MAINTENANCE

1. Dirt should not be allowed to accumulate on the outdoor coils or other parts in the air circuit. Clean as often as necessary to keep the unit clean. Use a brush, vacuum cleaner attachment, or other suitable means.
2. The outdoor fan motor bearings are permanently lubricated and do not require periodic oiling.
3. If the coil needs to be cleaned, it should be washed with Calgon Coilclean (mix one part Coilclean to seven parts water). Allow solution to remain on coil for 30 minutes before rinsing with clean water. Solution should not be permitted to come in contact with painted surfaces.
4. Refer to the furnace or air handler instructions for filter and blower motor maintenance.
5. The indoor coil and drain pan should be inspected and cleaned regularly to prevent odors and assure proper drainage.

CAUTION

IT IS UNLAWFUL TO KNOWINGLY VENT, RELEASE OR DISCHARGE REFRIGERANT INTO THE OPEN AIR DURING REPAIR, SERVICE, MAINTENANCE OR THE FINAL DISPOSAL OF THIS UNIT.

COOLING CHARGE TABLE IS ON THE INSIDE OF THE CONTROL BOX COVER.

Outdoor Unit	18	24	30	35	36	42	48	60
Defrost Jumper Pin Setting	2	2	2	3	3	2	4	2

SECTION XI: WIRING DIAGRAM

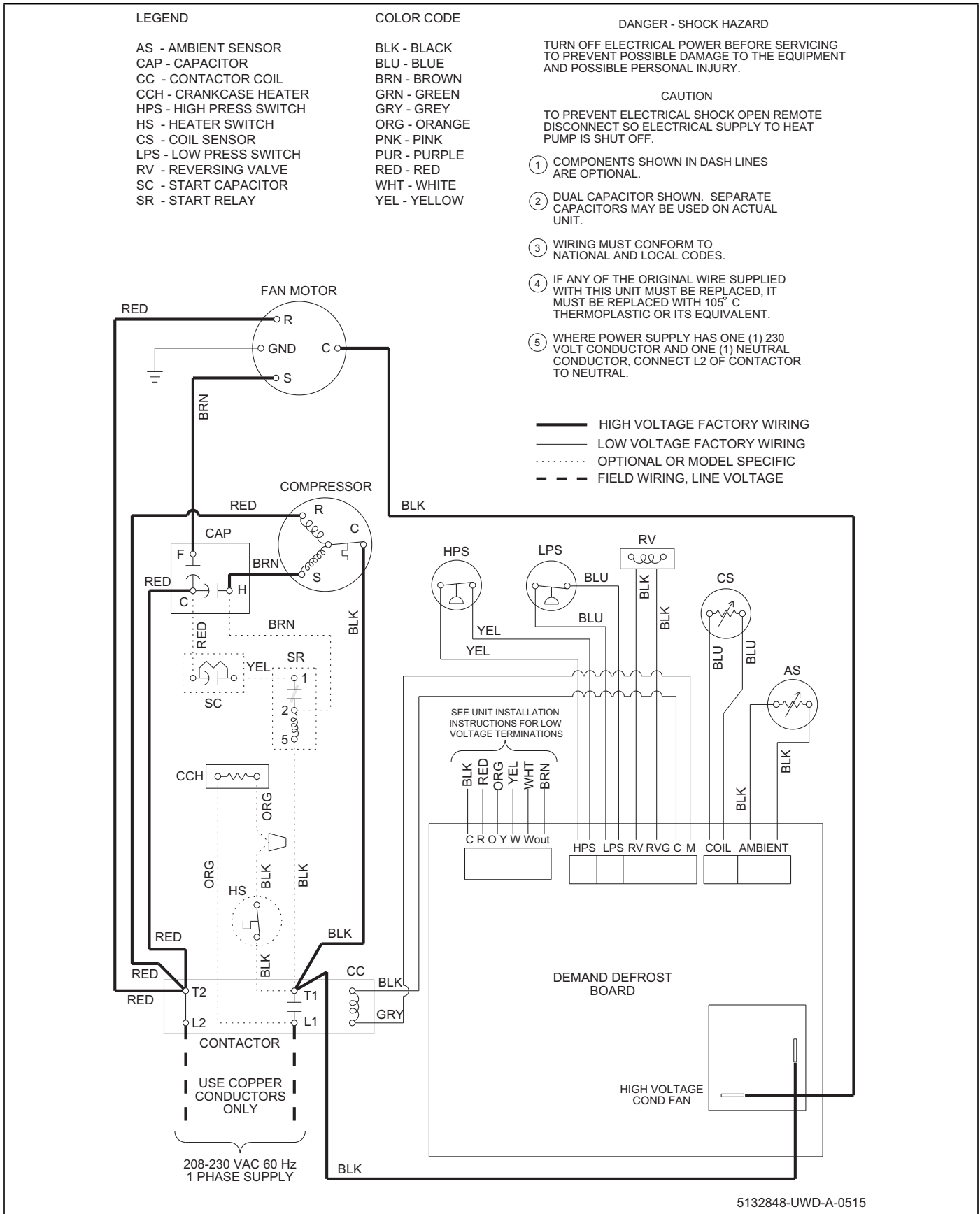

FIGURE 15: Wiring Diagram - Single Phase - 208/230V (Demand Defrost)

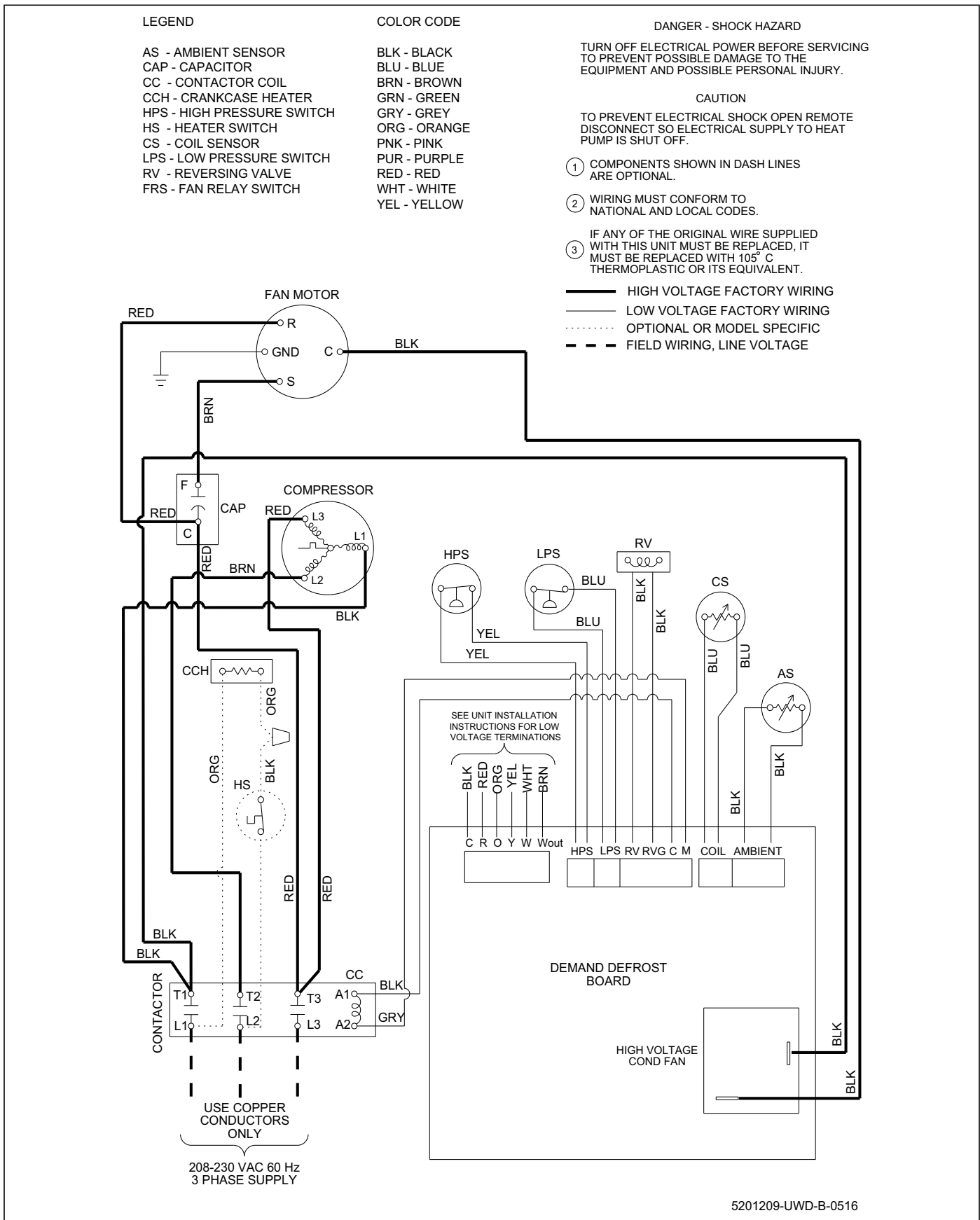

FIGURE 16: Wiring Diagram - Three Phase - 208/230V (Demand Defrost)

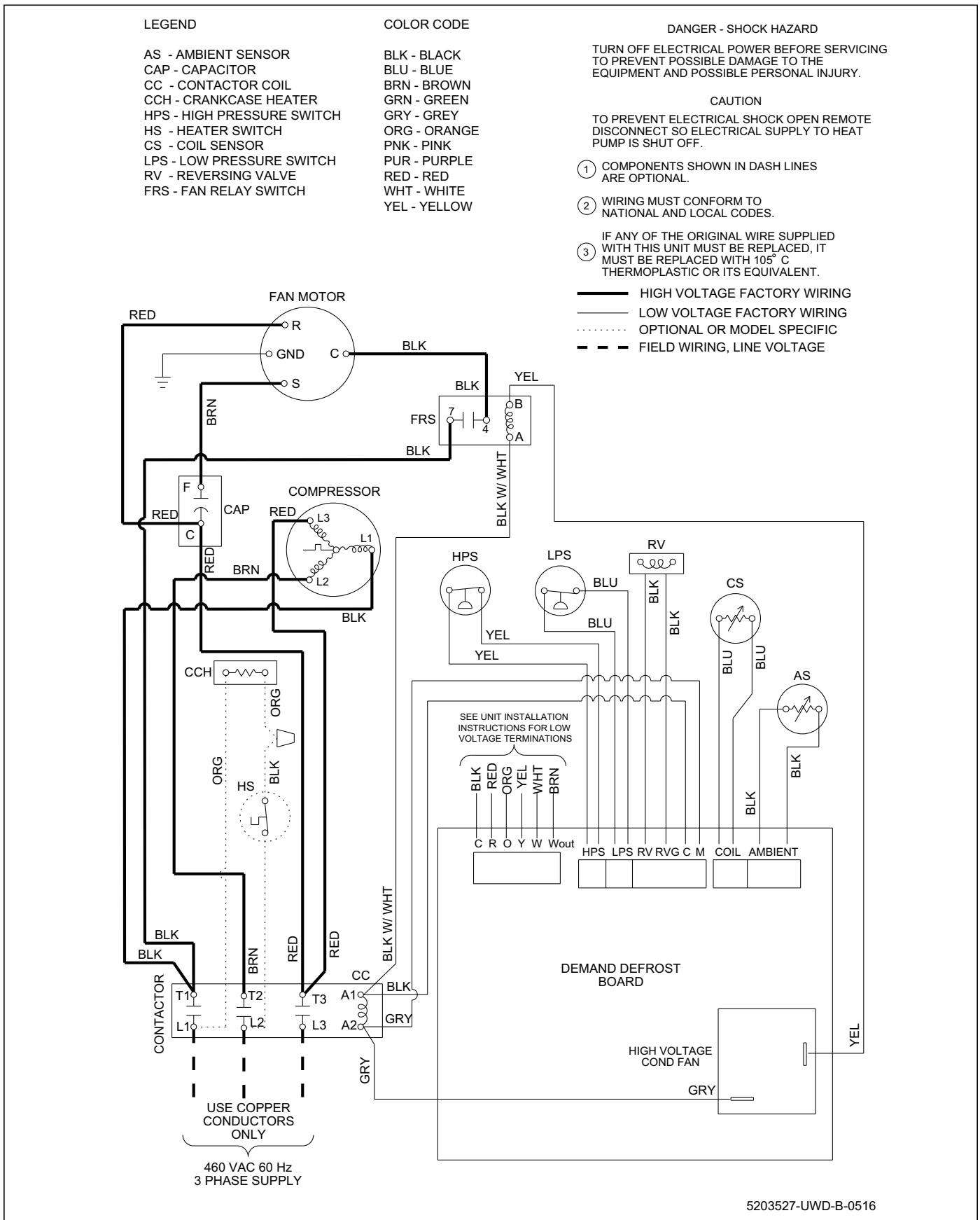

FIGURE 17: Wiring Diagram - Three Phase - 460V (Demand Defrost)

NOTES

SECTION XII: START UP SHEET

Heat Pump and Supplementary Heat Start-Up Sheet

Proper start-up is critical to customer comfort and equipment longevity

Start-Up Date Technician Performing Start-Up Installing Contractor Name **Owner Information**Name Address City State or Province Zip or Postal Code **Equipment Data** Upflow Downflow Horizontal Left Horizontal RightIndoor Unit Model # Indoor Unit Serial # Indoor Coil Model # Indoor Coil Serial # Outdoor Unit Model # Outdoor Unit Serial # **Filter, Thermostat, Accessories**Filter Type Filter Size Filter Location(s) Thermostat Type Other System Equipment and Accessories **Connections -- Per Installation Instructions and Local Codes**

- Unit is level Supply plenum and return ducts are connected and sealed Refrigerant piping complete and leak tested
 Gas piping is connected (if applicable) Vent system is connected (if applicable)
 Condensate drain for indoor coil properly connected Condensate drain for furnace (if applicable)

Electrical: Line VoltageIndoor unit (volts AC) Outdoor unit (volts AC) Overcurrent Protection Breaker / Fuses Amperes

- Ground wire is connected Polarity is correct (120vac indoor units) black is L1 (hot), white is N (neutral)

Electrical: Low Voltage Thermostat wiring complete

- Heat anticipator is set to the recommended value listed in the Installation Instructions

Heat anticipator

recommended value Low voltage values: "R" and "C" at Indoor unit control board (volts AC) "R" and "C" Outdoor unit control board (volts AC) **Supplementary Heating Set-Up**Heating Type Electric Air Handler Natural Gas LP Gas (Requires LP Conversion Kit)Inlet Gas Pressure (in. w.c.) Manifold Gas Pressure (in. w.c.) LP Gas Conversion Kit Part # Used Calculated input in btuh - clock the gas meter (Nat Gas Only) LP Kit Installed By Electric Heat Kit Part # (if applicable) KW installed Rated BTU/H (furnaces) **Venting (if applicable)** Venting system properly sized, within the limitations of the charts in the installation instructions.Intake Size # of 90 Degree Ells # Of 45 Degree Ells Length Exhaust Size # of 90 Degree Ells # Of 45 Degree Ells Length

Air Side: System Total External Static Pressure

Supply static before indoor coil (in w.c.)	<input type="text"/>	Supply static after indoor coil (in w.c.)	<input type="text"/>
Return Static (in w.c.) before filter	<input type="text"/>	Return Static (in w.c.) after filter (furnace side)	<input type="text"/>
Total External Static Pressure	<input type="text"/>	Maximum Rated ESP (in w.c.)	<input type="text"/>

Cooling & Heat Pump Indoor Blower Set-Up	<input type="radio"/> ECM	COOL <input type="radio"/> A <input type="radio"/> B <input type="radio"/> C <input type="radio"/> D			
		ADJUST <input type="radio"/> A <input type="radio"/> B <input type="radio"/> C <input type="radio"/> D			
		DELAY <input type="radio"/> A <input type="radio"/> B <input type="radio"/> C <input type="radio"/> D			
	<input type="radio"/> X-13 <input type="radio"/> 1 <input type="radio"/> 2 <input type="radio"/> 3 <input type="radio"/> 4 <input type="radio"/> 5				
	<input type="radio"/> PSC <input type="radio"/> Low <input type="radio"/> Medium Low <input type="radio"/> Medium <input type="radio"/> Medium High <input type="radio"/> High				
Return Air: <input type="text"/> Dry Bulb <input type="text"/>	Wet Bulb <input type="text"/>	Supply Air: <input type="text"/> Dry Bulb <input type="text"/>	Wet Bulb <input type="text"/>	Temperature Drop <input type="text"/>	Outside Air: <input type="text"/> Dry Bulb <input type="text"/>

Supplementary Heating Indoor Blower Set-Up	<input type="radio"/> ECM	HEAT <input type="radio"/> A <input type="radio"/> B <input type="radio"/> C <input type="radio"/> D		
	<input type="radio"/> X-13 <input type="radio"/> 1 <input type="radio"/> 2 <input type="radio"/> 3 <input type="radio"/> 4 <input type="radio"/> 5			
	<input type="radio"/> PSC <input type="radio"/> Low <input type="radio"/> Medium Low <input type="radio"/> Medium <input type="radio"/> Medium High <input type="radio"/> High			
	Return Air: <input type="text"/> Dry Bulb <input type="text"/>	Wet Bulb <input type="text"/>	Supply Air: <input type="text"/> Dry Bulb <input type="text"/>	Wet Bulb <input type="text"/>

Defrost Control Board
Fill in the information i.e.. "ON", "OFF" or the appropriate "Value" for the fields that apply to the defrost control board installed

YorkGuard VI Demand Defrost Time and Temperature

Low Temp Cut Out Balance Point Defrost Curve Y2 Lock FFUEL Switch Point

Hot Heat Pump Bonnet Sensor Present Run Time: Time and Temperature board only 30, 60 or 90 minutes

Refrigerant Charge and Metering Device

R-410A TXV Fixed Orifice

Additional Lineset Length Adder per foot - lbs. Oz.

Elbows # 45s Total Added - lbs. Oz.

Orifice Size Liquid Line Temp High Side Pressure Suction Line Temp Low Side Pressure

TXV # Subcooling Superheat

Cycle Test

- Operate the unit through several heating cycles from the thermostat, noting and correcting any problems
- Operate the unit through continuous fan cycles from the thermostat, noting and correcting any problems
- Operate the unit through a cooling cycles, noting and correcting any problems
- Operate the unit through an emergency heating cycles, noting and correcting any problems

Clean Up

Installation debris disposed of and indoor and outdoor areas cleaned up?

Owner Education

- Provide owner with the owner's manual
- Explain operation of system to equipment owner
- Explain thermostat use and programming (if applicable) to owner
- Explain the importance of regular filter replacement and equipment maintenance

Comments Section